



EJOT®

EJOT FDS®

The Flow-Drill Screw for
High-Strength Sheet
Joints



EJOT® The Quality Connection

Content

| | | |
|----|-------|--|
| 3 | | The Product |
| 5 | | The FDS® |
| 6 | | Designs |
| 10 | | Design Recommendations |
| 12 | | Installation Instruction |
| 14 | | Static Strength Properties |
| 15 | | Performance Characteristics |
| 16 | | Joining without Pilot and Clearance Hole |
| 18 | | EJOT – Your System Partner |

Imprint

Editor:

EJOT GmbH & Co. KG
Industrial Fasteners Division
57319 Bad Berleburg
Germany

Print:

Druckerei Schlabach GmbH & Co. KG
57339 Erndtebrück

© by EJOT GmbH & Co. KG

EJOT®, FDS®, ALtracs® and EJOMAT® are registered trademarks of EJOT GmbH & Co. KG.

TORX®, TORX PLUS® and AUTOSERT® are registered trademarks of Acument Intellectual Properties LLC.

All technical data may be subject to technical improvements.

Convincing facts about the EJOT FDS® joint

- removable and high-strength screw joint, without part preparations like punching or drilling
- no problems regarding hole overlapping of clearance and pilot hole
- no material waste while forming the through draught / no chips during thread forming
- several metric threads are engaged
- high safety margin due to large distance between installation and stripping torque (high assembly reliability)
- high shearing strength and pull-out force
- assembly in different sheet surfaces is possible
- high break loose torque and vibration resistance
- repeat assemblies possible with standard machine screws
- earthing assemblies (according to DIN VDE 0700) are practical
- easy to disassemble and recyclable
- low overall joint costs





Secure screw joints for steel and aluminium sheets

Due to its good processing and performance characteristics, steel is still the most important material in the sheet metal processing industry but the competition from lighter materials, such as aluminium, is increasing. For this reason the steel industry developed a number of new sheet materials over the last few years which feature high strengths and at the same time good forming characteristics. In addition to the typical deep-drawn, mild, unalloyed steels for coldforming (acc. to DIN EN 10130) the micro-alloyed thin sheets with higher yield strength H240M (ZStE 260) – H400M (ZStE 420) according to DIN EN 10268 (SEW093) and the dual phase steel type DP according to SEW 097, part 2, should be mentioned, since both materials play a significant role in the field of high strength sheet assemblies.

For forgeable aluminium alloy in the automotive industry mainly thermal hardenable AlMgSi alloys from the 6000 group in the strength grade T4 up to T6 are used in addition to the non-hardenable alloys of the 500 group. The T4 / T5 grades are preferred for sheet material and T6 for the extrusion profiles. The maximum utilisation of the respective steel and aluminium properties often requires a reconsideration of the commonly used assembly methods in particular when joining different materials.



Example in practice: white-good industry

The flow drilling EJOT FDS® Screw enables a higher-strength joint due to larger thread engagement in the formed draught.

The female metric thread, formed without producing chips during fastening, is true to gauge and for that reason a common metric screw can be used in case of repairs.

Due to the tight fitting engagement of several threads the screw joint is waterproof and gas-tight and it can transfer high pull-out and shear forces. The heat development during flow-drilling is harmless, because it is below the recrystallisation temperature of the assembly materials and is counted towards the low temperature joining methods. The low remaining temperature is sufficient to shrink the formed draught onto the screw after assembly which guarantees a high dynamic safety.

For this reason additional safety elements, such as adhesive coatings, can be eliminated.

Since component preparations, such as pre-drilling or punching are not necessary, known tolerance problems and lining up of clearance holes are a thing of the past. The one-sided accessibility of the component enables assembly into hollow profiles or extrusions similar to other joining methods.



Example in practice: automotive industry

Stages of the FDS® assembly

1. Warming up of the sheet through end load and high rotation speed
2. Penetration into the material
3. Forming of the through draught
4. Chipless forming of female machine thread
5. Engagement of full threads
6. Tightening with the pre-set torque

Operational Characteristics

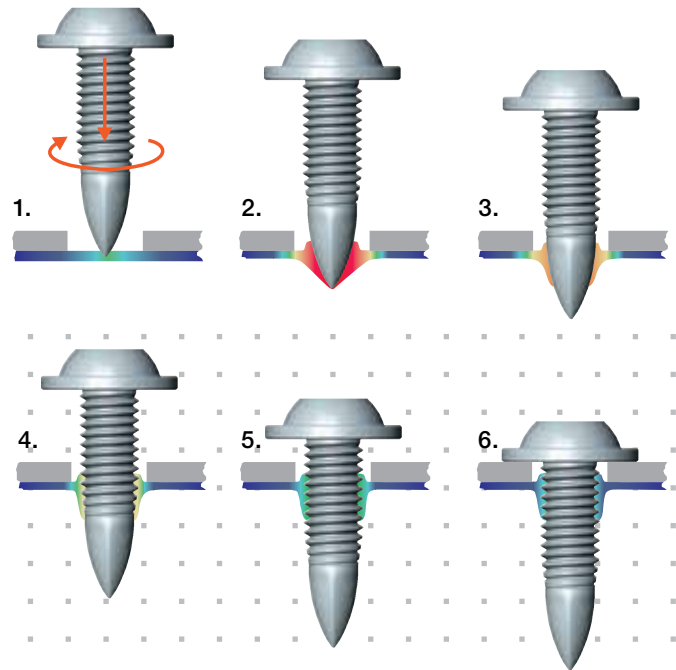

Temperature pattern of a FDS® joint

1. Heating
2. Penetrating
3. Through draught forming
4. Thread forming
5. Engagement of full threads
6. Tightening

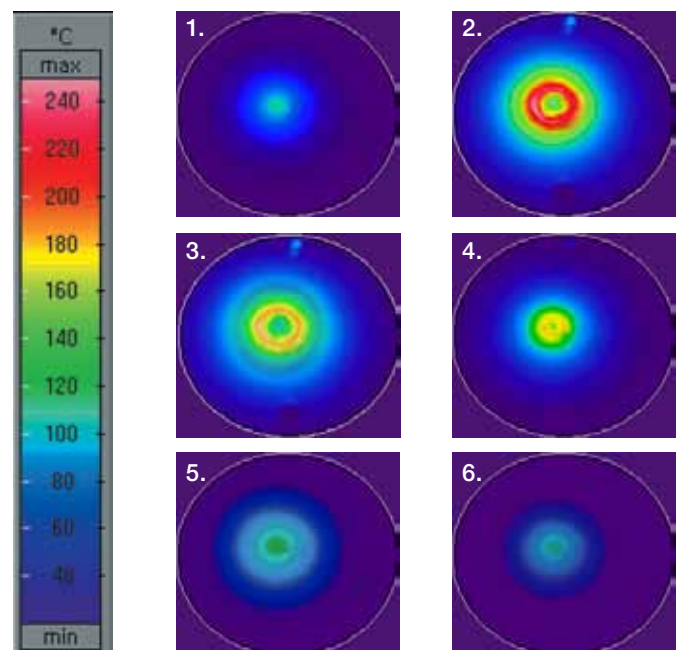

Fastening parameter

Material: 0,8 mm steel plate
DC 04 (without pilot hole)

Screw: EJOT FDS® M 3,5

Driver speed: 2300 rpm

Due to the numerous possible sheet metal applications, several styles of the EJOT FDS® Screw have been developed.

The Standard type is preferred for automated assembly without pilot hole.

For assembly with hand-held fastening equipment a pilot hole in combination with the PKS Type is useful.

For manual assembly without pilot hole the FDS® Type BS is recommended. In this case please consider the chipping that occurs during drilling.

With the PKS and BS types, a pilot hole or pre-drilling facilitates the penetration of the sheet metal, and a reduction of the end load by 50 % is possible. The diameter of pilot hole or the drill point is relatively small and therefore the remaining sheet metal also forms a draught.

The diagram on page 11 shows the pilot hole diameters.

Degree of dependence of the end load on screw point design and pilot hole at constant assembly times.

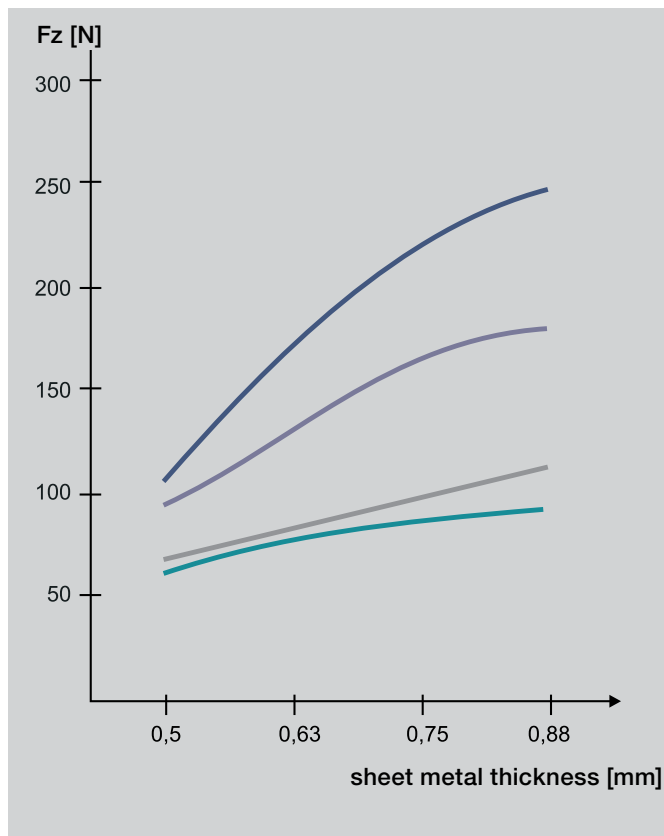

- type standard without prepunching
- type standard with punch mark 60°
- type PKS with prepunching
 at 0,50 mm sheet metal thickness Ø 2,2 mm
 at 0,63 mm sheet metal thickness Ø 2,4 mm
 at 0,75 mm sheet metal thickness Ø 2,6 mm
 at 0,88 mm sheet metal thickness Ø 2,8 mm
- type BS with drill point Ø 2,4 mm

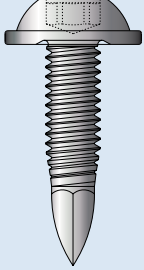
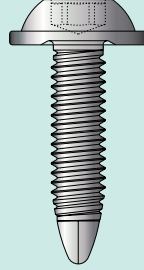
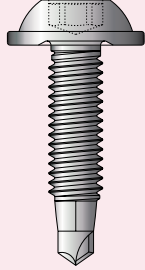
| Type | Standard | PKS | BS |
|---|--|--|--|
|  |  |  |  |
| Screw material | Case hardened mild steel Through hardened steel through hardened steel + inductive hardening | Case hardened mild steel Through hardened steel through hardened steel + inductive hardening | case hardened mild steel |
| Surfaces | <p>Chrom VI-free surfaces: zinc clear / blue passivated zinc clear / blue passivated + EJOSEAL (240h resistance to Zn-corrosion) ZnFe or ZnNi, transparent passivated (with or without black top coats) zinc flake coatings (with or without black top coats) ZnNi / black passivated</p> <p>Different plating upon request!</p> | | |
| Application | fastening without prepunching | fastening with prepunching | fastening without prepunching |
| Installation material | steel 0,4 - 1,8 mm aluminium 0,8 - 5,0 mm magnesium 0,8 - 4,0 mm | steel 0,4 - 2,0 mm aluminium 0,8 - 4,0 mm magnesium 0,8 - 4,0 mm stainless steel 0,4 - 1,5 mm | steel 0,4 - 1,5 mm aluminium 0,8 - 2,0 mm magnesium 0,8 - 2,0 mm |
| Characteristics | <p>tolerance-free assembly, because no misalignment with clearance hole possible</p> <p>suited especially for automated assembly</p> <p>extremely high joint strength</p> <p>one-sided assembly</p> <p>ideal screw for safe assembly and dynamic loads</p> <p>the through draught is about 3 times as high as the original sheet metal thickness</p> | <p>due to the bigger clearance hole compared to the smaller pilot hole, some tolerances can be compensated (S. 11)</p> <p>preferable for manual assembly</p> <p>low end load</p> <p>one-sided assembly</p> <p>the through draught is about twice as high as the original sheet metal thickness</p> | <p>tolerance-free assembly, because no misalignment with clearance hole possible</p> <p>suited for automated and manual assembly</p> <p>low end load</p> <p>one-sided assembly</p> <p>the through draught is about twice as high as the original sheet metal thickness</p> |

WN 2141

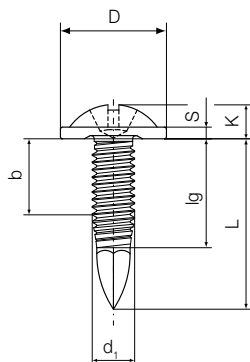

WN 2142

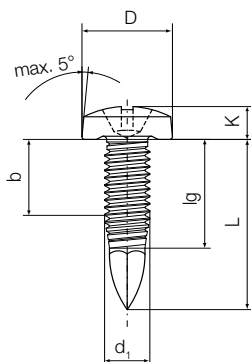

WN 2143

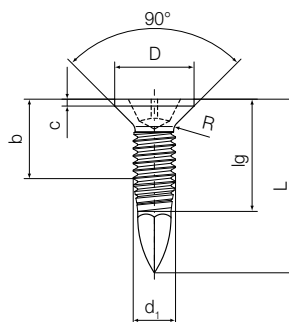

WN 2147

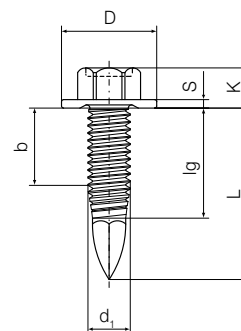

H-cross recess

Z-cross recess

TORX®

**TORXplus® /
AUTOSERT®**



In case of manual assembly with TORX® it is recommended to use a TORXALIGN® bit, e.g. STICK FIT bits by TORX PLUS® drives.

All cross recess and TORX® drives are also available as combi drives.

| EJOT FDS® | Nominal-Ø | | M 3 | M 3,5 | M 4 | M 5 | M 6 |
|-----------|-------------------|----------------|-----|-------|-----|-----|-----|
| | External thread-Ø | d ₁ | 3,0 | 3,5 | 4,0 | 5,0 | 6,0 |

| WN 2141 | Head-Ø | D | | | | | | |
|----------------|-------------------|---|------|------|-------|-------|-------|------|
| | | | 7,50 | 8,50 | 10,00 | 12,00 | 14,00 | |
| | Head height | K | 2,40 | 2,50 | 3,20 | 4,00 | 4,60 | |
| | Washer thickness | s | 0,80 | 0,90 | 1,10 | 1,30 | 1,50 | |
| H-cross-recess | penetration depth | t | min. | 1,07 | 1,33 | 1,98 | 2,24 | 2,84 |
| | | | max. | 1,70 | 1,96 | 2,61 | 2,90 | 3,50 |
| Z-cross-recess | penetration depth | t | min. | 1,08 | 1,40 | 2,01 | 2,27 | 2,91 |
| | | | max. | 1,54 | 1,86 | 2,47 | 2,73 | 3,37 |
| | Cross size H/Z | | 1 | 2 | 2 | 3 | 3 | |

| WN 2142 | Head-Ø | D | | | | | | |
|----------------|-------------------|---|------|------|------|-------|-------|------|
| | | | 6,00 | 7,00 | 8,00 | 10,00 | 12,00 | |
| | Head height | K | 2,40 | 2,70 | 3,10 | 3,80 | 4,60 | |
| H-cross-recess | penetration depth | t | min. | 1,70 | 1,74 | 2,04 | 2,77 | 3,03 |
| | | | max. | 2,00 | 2,24 | 2,54 | 3,27 | 3,53 |
| Z-cross-recess | penetration depth | t | min. | 1,68 | 1,65 | 1,90 | 2,64 | 3,02 |
| | | | max. | 1,93 | 2,11 | 2,36 | 3,10 | 3,48 |
| | Cross size H/Z | | 1 | 2 | 2 | 2 | 3 | |

| WN 2143 | Head-Ø | D | | | | | | |
|----------------|-------------------|------------------|------|------|------|------|-------|------|
| | | | 5,60 | 6,50 | 7,50 | 9,20 | 11,00 | |
| | Cyl. head height | c _{max} | 0,55 | 0,55 | 0,65 | 0,75 | 0,85 | |
| | Radius | R _{max} | 0,80 | 0,95 | 1,00 | 1,30 | 1,60 | |
| H-cross-recess | penetration depth | t | min. | 1,50 | 1,40 | 1,90 | 2,10 | 2,80 |
| | | | max. | 1,80 | 1,90 | 2,40 | 2,60 | 3,30 |
| Z-cross-recess | penetration depth | t | min. | 1,48 | 1,34 | 1,60 | 2,05 | 2,46 |
| | | | max. | 1,73 | 1,80 | 2,06 | 2,51 | 2,92 |
| | Cross size H/Z | | 1 | 2 | 2 | 2 | 3 | |

| WN 2147 | Washer-Ø | D | 7,50 | 8,30 | 9,00 | 11,00 | 13,00 |
|---------|--------------------|-----|------|------|------|-------|-------|
| | Head height | K | 3,00 | 3,40 | 3,80 | 4,30 | 5,00 |
| | Washer thickness | s | 0,60 | 0,80 | 0,80 | 1,00 | 1,20 |
| | Width across flats | A/F | 5,00 | 5,50 | 5,50 | 7,00 | 8,00 |

WN 2151

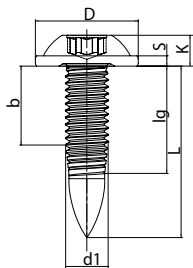

WN 2152

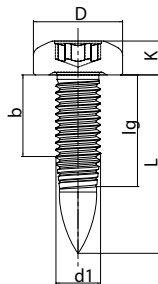

WN 2154

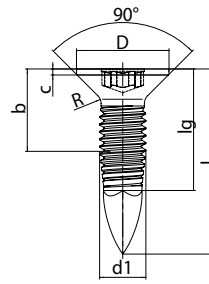

All WN-specifications according to types:

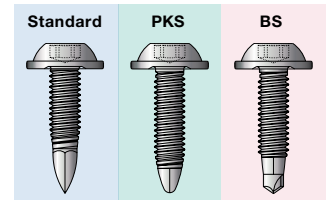

Ordering Example:

Description of EJOT FDS® screw Ø 4 mm and length 20 mm

- a) type Standard with Z-cross recess according to WN 2141:
- b) type PKS with TORX® recess according to WN 2152:
- c) type BS with hexagonal heat according to WN 2147:

EJOT FDS® screw M4 x 20 WN2141-Z

EJOT FDS® screw M4 x 20 PKS WN2152

EJOT FDS® screw M4 x 20 BS WN2147

| EJOT FDS® | Nominal-Ø | | M 3 | M 3,5 | M 4 | M 5 | M 6 | |
|----------------|-------------------|------------------|-------------------|-------|-------|-------|-------|------|
| | External thread-Ø | d ₁ | 3,0 | 3,5 | 4,0 | 5,0 | 6,0 | |
| WN 2151 | Head-Ø | D | 7,50 | 8,50 | 10,00 | 12,00 | 14,00 | |
| | Head height | K | 2,70 | 2,90 | 3,60 | 3,90 | 4,80 | |
| | Washer thickness | s | 0,70 | 0,80 | 1,00 | 1,20 | 1,40 | |
| | TORX® | | T10 | T15 | T20 | T25 | T30 | |
| | Penetration depth | t | A _{max.} | 2,80 | 3,35 | 3,95 | 4,50 | 5,60 |
| min. | | | 1,00 | 1,20 | 1,40 | 1,60 | 2,00 | |
| max. | | | 1,30 | 1,50 | 1,80 | 2,00 | 2,40 | |
| WN 2152 | Head-Ø | D | 6,00 | 7,00 | 8,00 | 10,00 | 12,00 | |
| | Head height | K | 2,70 | 2,90 | 3,60 | 3,90 | 4,80 | |
| | TORX® | | T10 | T15 | T20 | T25 | T30 | |
| | Penetration depth | t | A _{max.} | 2,80 | 3,35 | 3,95 | 4,50 | 5,60 |
| | | | min. | 1,00 | 1,20 | 1,40 | 1,60 | 2,00 |
| max. | | | 1,30 | 1,50 | 1,80 | 2,00 | 2,40 | |
| WN 2154 | Head-Ø | D | 5,60 | 6,50 | 7,50 | 9,20 | 11,00 | |
| | Cyl. Head height | c _{max} | 0,60 | 0,65 | 0,70 | 0,75 | 0,85 | |
| | TORX® | | T10 | T15 | T20 | T25 | T30 | |
| | Penetration depth | t | A _{max.} | 2,80 | 3,35 | 3,95 | 4,50 | 5,60 |
| | | | min. | 0,75 | 0,85 | 1,10 | 1,15 | 1,40 |
| max. | | | 1,10 | 1,15 | 1,55 | 1,55 | 1,80 | |

Special variations / Examples

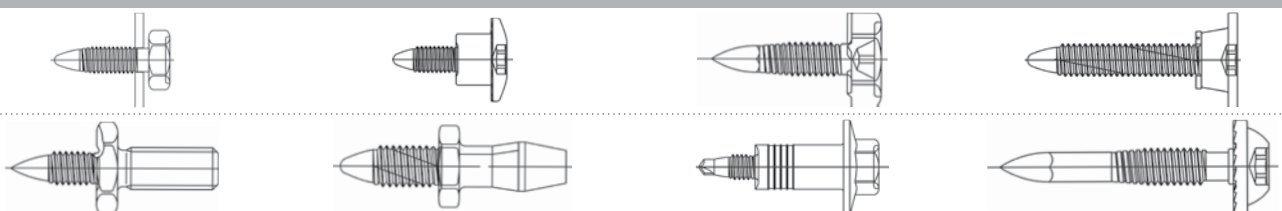

Special variations are available.

Please contact the EJOT application engineers to realise your multifunctional design.

Design Recommendations

In many applications the EJOT FDS® can be used with existing products.

The following notes are for the design of existing and new products.

The **usable thread length b** of EJOT FDS® screws is depending on the part's thickness S_1 and the metal sheet thickness S_2 .

It is given by:

$$b = S_1 + 3 \times S_2 \text{ without prepunching (type Standard)}$$

$$b = S_1 + 2 \times S_2 \text{ with prepunching (type PKS and BS)}$$

The corresponding nominal screw length L can be taken from the accompanying table below.

Example

$S_1 = 4,50 \text{ mm}$, $S_2 = 0,75 \text{ mm}$:

without prepunching

$$b = (4,50 + 3 \times 0,75) \text{ mm} = 6,75 \text{ mm}$$

with prepunching

$$b = (4,50 + 2 \times 0,75) \text{ mm} = 6,00 \text{ mm}$$

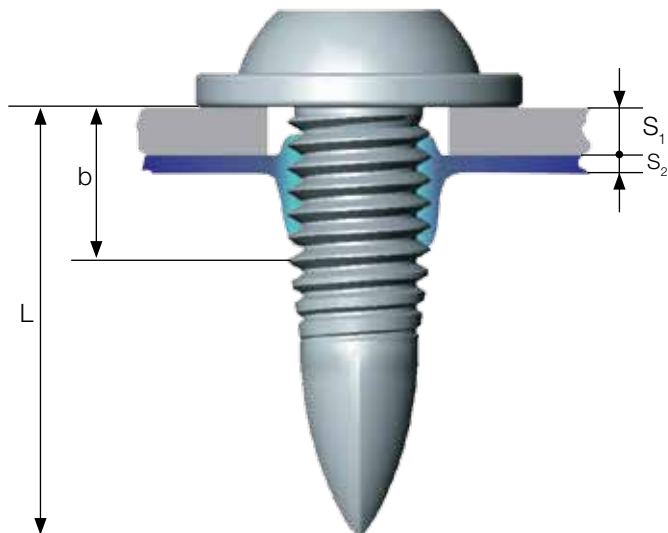

For an FDS® M5 Standard (without pilot hole) the recommendation (according to the diagram below) is an effective thread length of $b = 6,90 \text{ mm}$ with a corresponding nominal length of $L = 18 \text{ mm}$.

For assembly with pilot hole a FDS® M5 x 14 PKS with an effective thread length of $b = 6,20 \text{ mm}$ and a nominal length of $L = 14 \text{ mm}$.

Manufacturing range

| EJOT FDS® screw | M3 | | | M3,5 | | | M4 | | | M5 | | | M6 | | |
|----------------------|------------------------------------|-------|----|----------|-------|-------|----------|-------|-------|----------|-------|-------|----------|-------|-------|
| | Standard | PKS | BS | Standard | PKS | BS | Standard | PKS | BS | Standard | PKS | BS | Standard | PKS | BS |
| Length L [mm] | Usable thread length b [mm] | | | | | | | | | | | | | | |
| 9 + 0,8 | 2,40 | 4,70 | | | | | | | | | | | | | |
| 10 + 0,8 | 3,40 | 5,70 | | 2,40 | 4,90 | 4,60 | | | | | | | | | |
| 12 + 0,8 | 5,40 | 7,70 | | 4,40 | 6,90 | 6,60 | 3,10 | 5,70 | 5,40 | | | | | | |
| 14 + 0,8 | 7,40 | 9,70 | | 6,40 | 8,90 | 8,60 | 5,10 | 7,70 | 7,40 | 2,90 | 6,20 | 6,10 | | | |
| 16 + 0,8 | 9,40 | 11,70 | | 8,40 | 10,90 | 10,60 | 7,10 | 9,70 | 9,40 | 4,90 | 8,20 | 8,10 | 2,90 | 6,60 | 5,90 |
| 18 + 0,8 | 11,40 | 13,90 | | 10,40 | 12,90 | 12,60 | 9,10 | 11,70 | 11,40 | 6,90 | 10,20 | 10,10 | 4,90 | 8,60 | 7,90 |
| 20 + 0,8 | | | | 12,40 | 14,90 | 14,60 | 11,10 | 13,70 | 13,40 | 8,90 | 12,20 | 12,10 | 6,90 | 10,60 | 9,90 |
| 25 + 0,8 | | | | | | | 16,10 | 18,70 | 18,40 | 13,90 | 17,20 | 17,10 | 11,90 | 15,60 | 14,90 |
| 30 + 0,8 | | | | | | | | | | 18,90 | 22,20 | 22,10 | 16,90 | 20,60 | 19,90 |
| 35 + 1,0 | | | | | | | | | | | | | 21,90 | 25,60 | 24,90 |
| 40 + 1,0 | | | | | | | | | | | | | 26,90 | 30,60 | 29,90 |
| 45 + 1,0 | | | | | | | | | | | | | 31,90 | 35,60 | 34,90 |
| 50 + 1,0 | | | | | | | | | | | | | 36,90 | 40,60 | 39,90 |

Special lengths upon request.

- - - - = minimum length for countersunk heads

Design Recommendations

Recommended clearance hole d_b [mm]

Flow-drilling with the EJOT FDS® Screw causes a small portion of the formed part to flow against the fastening direction and to create a bulge which has to be absorbed by the clearance hole of the component to be fastened. For this reason we recommend the following hole diameter.

| FDS® | M3 | M3,5 | M4 | M5 | M6 |
|-------|-----------|-----------|-----------|-----------|-----------|
| d_b | 3,6 - 4,0 | 4,3 - 4,8 | 5,1 - 5,7 | 6,7 - 7,4 | 8,2 - 9,1 |

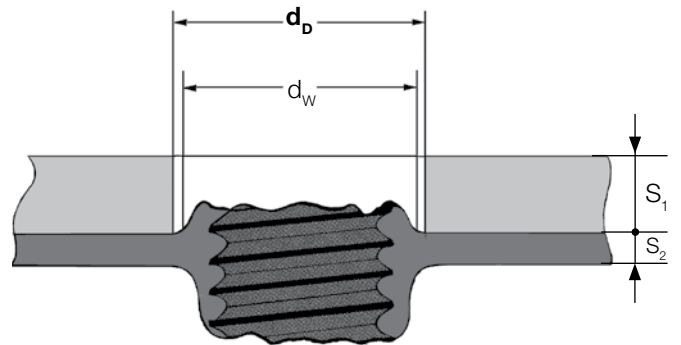

Clearance hole d_b for clamped material
 d_w : bulge diameter
 d_b : clearance hole

Recommended hole diameter d_v [mm]* for the PKS type

The optimum hole diameter depends on the respective range of requirements on the joint and should be specified according to the application.

| FDS® | M3 | M3,5 | M4 | M5 | M6 | |
|----------------------------|-------|-----------|-----------|-----------|-----------|-----------|
| sheet thickness S_2 [mm] | 0,5 | 1,0 - 1,4 | 1,2 - 1,7 | 1,5 - 2,0 | 1,8 - 2,5 | - |
| | 0,63 | 1,2 - 1,6 | 1,4 - 1,8 | 1,6 - 2,2 | 1,8 - 2,5 | 2,0 - 3,0 |
| | 0,75 | 1,6 - 1,8 | 1,6 - 2,0 | 1,8 - 2,5 | 2,0 - 2,8 | 2,2 - 3,2 |
| | 0,88 | 1,8 - 2,2 | 1,8 - 2,3 | 2,0 - 2,6 | 2,2 - 3,0 | 2,5 - 3,5 |
| | 1,00 | - | 1,8 - 2,4 | 2,2 - 2,8 | 2,6 - 3,4 | 2,8 - 3,8 |
| | 1,25 | - | - | 2,4 - 3,0 | 3,0 - 3,8 | 3,4 - 4,5 |
| | 1,50 | - | - | - | 3,4 - 4,2 | 3,8 - 5,0 |
| | >1,50 | - | - | - | 4,2 - 4,6 | 5,2 - 5,6 |

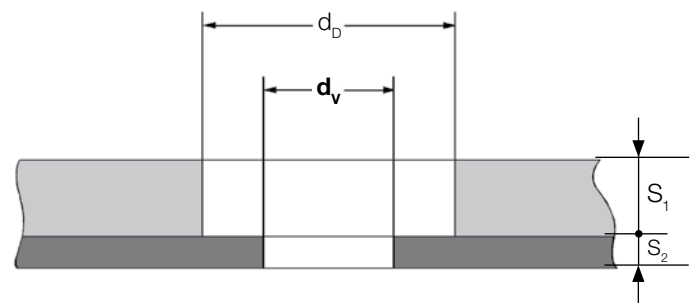

Pilot hole d_v for the installation part (type PKS)

d_v : pilot hole diameter
 d_b : clearance hole

* With lasered holes please consider hole edge hardening.
 Valid for sheet metal / sheet metal joints made of mild, unalloyed steels for coldforming acc. to DIN EN 10130 (DC01 - DC07)

Note for manual assembly

For manual assembly into sheet metal thicker than: steel > 0,80 mm; Aluminium > 1,25 mm a higher end load is necessary. As a result we recommend the use of either a pilot hole or our FDS® type BS.

When fastening into steel > 2,0 mm we recommended the use of the EJOT Spiralform® screws or EJOT® self-drilling screws, for aluminium > 3,5 mm the use of the EJOT ALtracs® screws.

For more informations about the design and design or assembly recommendations please contact:
 phone +49 2751 529-123
 fax +49 2751 529-98 123
 e-mail: hotline@ejot.de

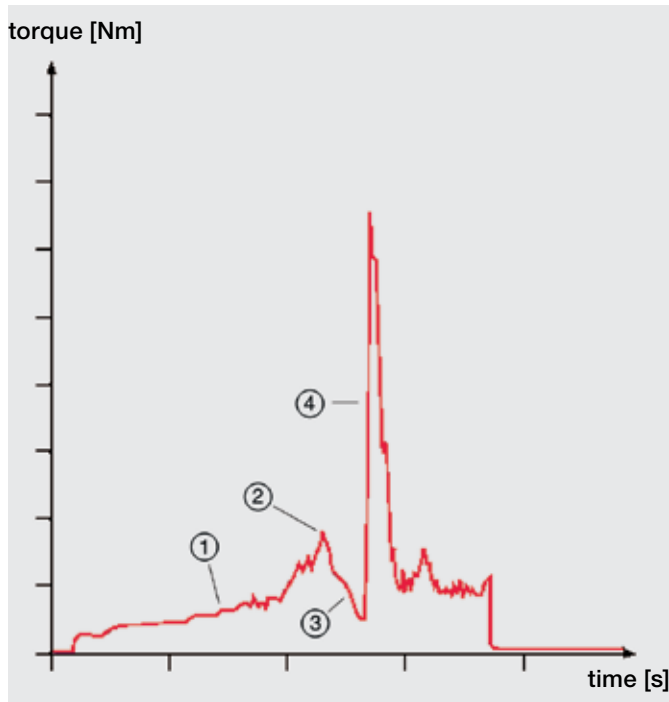

Fastening

During the fastening process the following graph of the installation torque can be observed over time.

- ① Through draught forming
- ② Thread forming
- ③ Engagement of full threads
- ④ Tightening

The fastening time necessary for EJOT FDS® mainly depends upon the flowdrilling process.

Parameters are:

- screw diameter
- type of screw point
- driver tool speed
- sheet thickness
- sheet quality / material specification
- end load
- part preparation yes / no

We will gladly determine the respective data for your individual application.



Robot-aided fastening system by Weber Schraubautomaten

Fastening equipment selection

A high driver speed and defined end load are necessary for the flow-drilling and for the thread forming and for tightening a high torque. This requires special tools that have been developed in cooperation with several manufacturers. Most manufacturers for manually operated and automatic fastening equipment offer screw drivers with speeds from 2000 to 5000 rpm.

The necessary assembly data such as driver speed and tightening torque depend on

- sheet thickness
- material strength
- surface treatment
- material of the connecting surface
- requirements of the screw joint

For manual assembly pneumatic screw drivers with torque controlled shut-off clutch.

For automated assembly both pneumatic and electric spindels (brushless DC or AC) are suitable.

To determine the parameters assembly tests in our application technology laboratory EJOT® APPLITEC can be carried out.

Auto body assembly of the
AUDI TT, with courtesy of
Audi AG



In the frame of the suitability examination of joining methods for high-strength sheet steel the University Paderborn (Germany), has tested the strength values of an FDS® joint regarding peeling and shearing strength.

The strength properties of fastening with FDS® were compared to other joining methods.

In addition to the two diagrams the strength value of an FDS® joint with additional one-component adhesive (hybrid) is pictured.

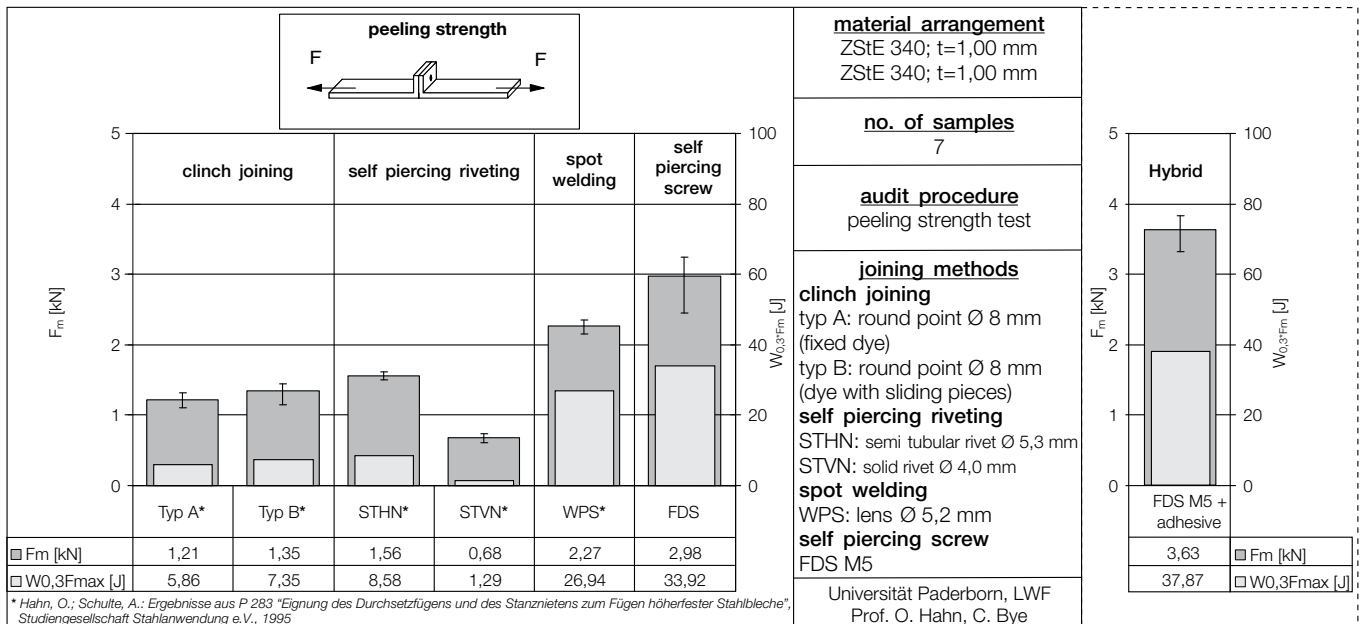

peeling strength F_m and energy absorption $W_{0,3Fm}$ of different joining methods in steel (ZStE 340)

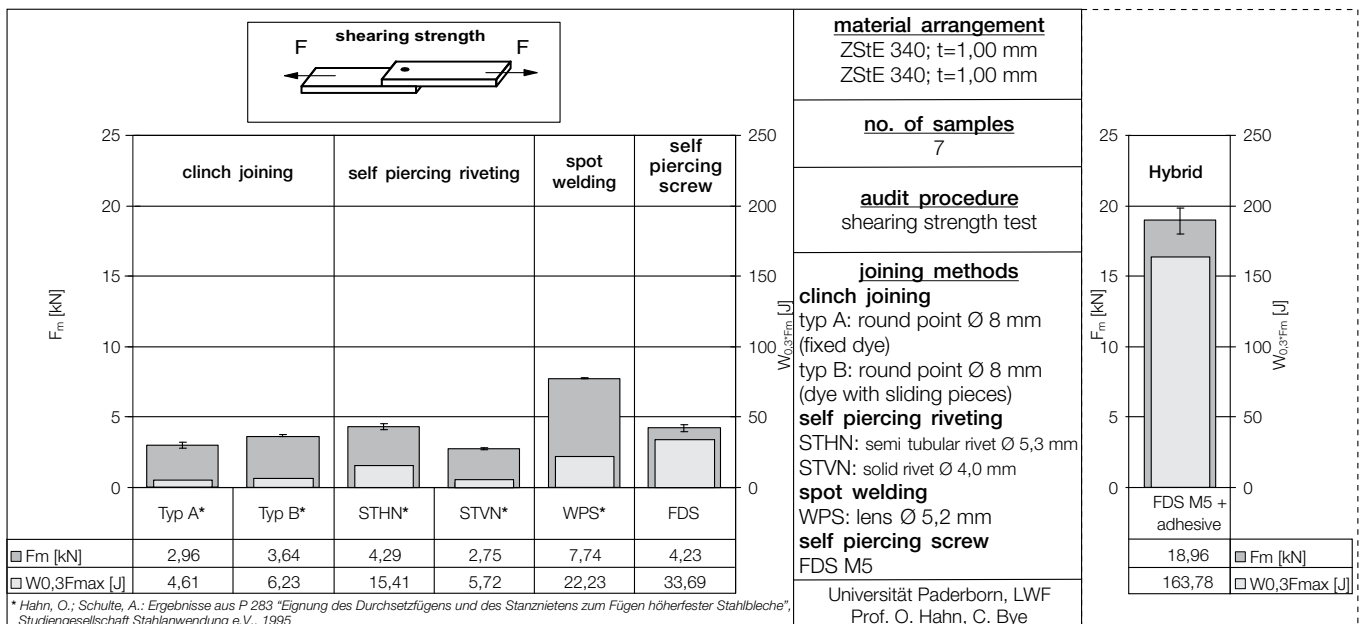

shearing strength F_m and energy absorption $W_{0,3Fm}$ of different joining methods in steel (ZStE 340)

In order to fully utilise the material properties of high-strength sheet steel the selection of suitable joining methods is decisive.

Spot-welded samples of dual phase steel DP-K30/50 compared to a soft non-alloy steel DC 04 have up to 3 to 4 times longer service life.

The joining method with FDS® Screws increases the service life of the dual phase steel compared to the soft non-alloy steel by up to 10 times.

The smaller pitch of the Wöhler curve of the FDS® joint compared to spot welding also indicates a decreased notch sensitivity of the screw joint.

Dynamic strength of EJOT FDS® joints

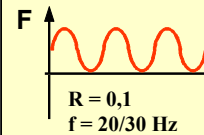
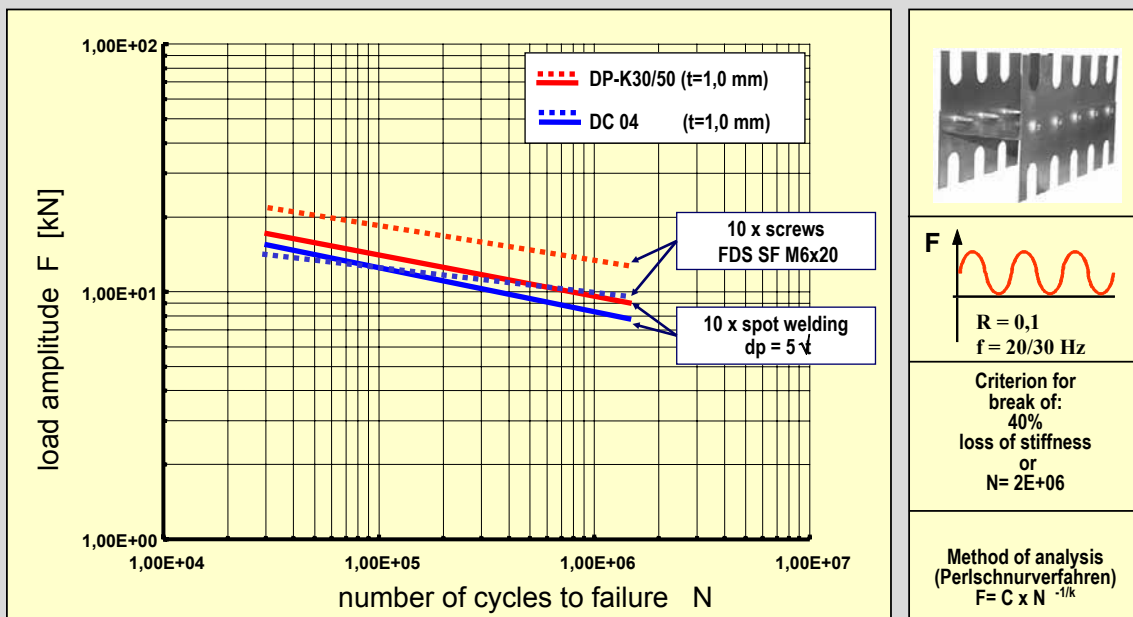

Criterion for break of:
40%
loss of stiffness
or
 $N = 2E+06$

Method of analysis
(Perlschnurverfahren)
 $F = C \times N^{-1/k}$



Function of joining without pilot and clearance hole



*Application example:
Aluminium sheet on extruded
aluminium profile*



*Application example:
Composite construction -
plastic on aluminium profile*

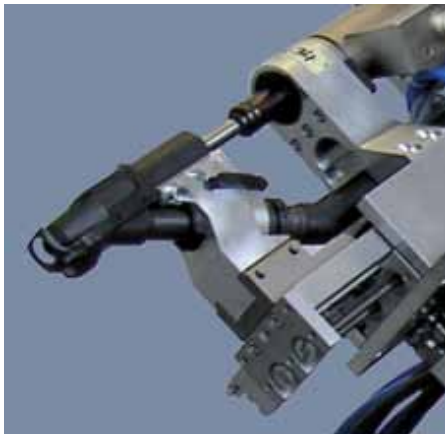

*Retainer under the nozzle of the fastening system
(Source: Weber Schraubautomaten)*

Modern space frame structures have high demands on the joining technology in the body shell work because of the composite construction and the oftentimes one-sided accessibility.

While the clamped components for joining the EJOT FDS® screw to the Audi TT were still pre-punched, this pre-punching was omitted for the Audi R8. For this the fastening parameters were adjusted and the geometry of the FDS® screw below the screw head was optimised, since a small amount of the material flows towards the fastening direction. While in the past this through hole was used for taking up the displaced material it is now being absorbed by the increased space below the screw head.

To fasten the FDS® screw it is fed automatically into the nozzle of the robot guided fastening equipment. Prior to the actual fastening process the retainer, which is positioned in front of the nozzle, pushes on the joint in order to minimise cracking between the two components during the fastening process. The spindle speed is increased simultaneously to the application of the axial load. The screw point pierces both components and forms a metric female thread without chips. When the screw head connects to the surface the displaced material is taken up by the screw head. Until reaching the tightening torque the screw clamps the two components and ensures a much stronger joint due to the larger thread engagement.

The material arrangement when fastening without pilot hole should be "thin in thick" or "soft in hard" respectively, since higher tightening torques can be reached and gaps between the two components can be minimised.

Stages of assembly:

1. Warming up
2. Penetration into the material
3. Forming of the extrusion
4. Thread forming
5. Full thread engagement
6. Tightening

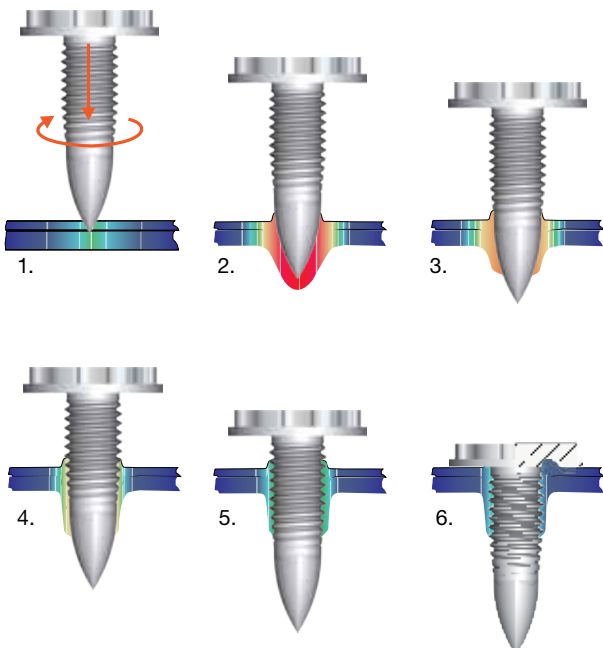

Process steps of the FDS® assembly without pilot hole



Your system partner

Test rack at APPLITEC



In-house seminar

Design Consultation

A major consideration of today's product manufacture is the basic need to be cost competitive.

The cost structure of the manufactured product is significantly influenced by the design.

Generally speaking, the development of a product, which represents about 10% of the overall costs, determines about 70% of the costs for the final product. Here the cost responsibility of the design engineer becomes evident, because he has to think about the adequate fastening technology already during the product conception stage. It is known that an alteration of the part during the production stage is much more expensive than an optimisation during the design conception stage.

To assist our customers in this process EJOT offers support during the design stage with comprehensive application engineering services. These services provide accurate information on product performance and result in design recommendations that can be used safely on the product line.

Consequent Application Engineering

The daily work with our customers and their application queries greatly influences our understanding of fastening technology and opens up possibilities for innovation. This way we consequently improve our products to meet customer demands and needs.

In addition to highly-qualified engineers and application engineering consultants our application laboratory, the EJOT APPLITEC, is at your disposition. Here we carry out a series of tests on the customer components and also develop new fastening solutions.

Our knowledge is passed on to our customers and this way supports their effort towards more rational fastening and assembly.

Detailed test reports, technical advice on site, acknowledged seminars and technical publications show our Know-How.



Test report

Logistics and Data Exchange

It is our aim to keep procurement and warehousing costs as low as possible by simultaneously offering product availability and quality.

With respect to simplified procuring processes, EJOT offers a variety of cost reducing procedures and services. The continued analysis of our customers' demands and advanced logistics procedures lead to high availability of our products.

Quality for Automated Assembly

Successful assembly automation means high utilisation of the equipment. The quality of the screw used for fastening can be a decisive factor for machine uptimes and a more efficient assembly process. Standard quality is not sufficient anymore.

The grade of purity offered by EJOMAT® Quality is 10 times higher than the usual standard quality which means less assembly down time costs: EJOMAT® Quality that pays for itself.

EJOT Sales Organisation

In addition to EJOT companies throughout Europe a growing number of Licensees in North & South America and Asia ensure the global availability of products and local support.

Contact details can be found on our homepage www.ejot.com.



Modern PPS-systems lead to high accuracy in supplying and short through-put times



EJOMAT® for fully automated assembly



EJOT GmbH & Co. KG

Industrial Fasteners Division
Im Herrengarten 1
57334 Bad Berleburg- Germany
P.O. Box 10 12 60
57302 Bad Berleburg- Germany
phone +49 2751 529-0
fax +49 2751 529-559
e-mail: industrie@ejot.de
Internet: www.ejot.com