



No. 731 | SEPTEMBER

# Bossard News

[Assembly Technology Expert](#) | Safety and quality through calculation ...

[Smart Factory Logistics](#) | The revolutionary cloud chain solution ...

[Product Solutions](#) | REACH and RoHS: An introduction to EU directives...

## EDITORIAL



### Dear customers,

The exceedingly positive first half of the year is now well behind us. I reported on the outlook for the second half of the year in the last issue of BOMI with a bit of skepticism. Now I can say with conviction that the boom in demand will extend well into the second half of the year. Except for the aviation industry, which is still suffering from the ever-changing travel restrictions, the upswing is very broadly supported – both geographically and when it comes to industry segments.

We are currently dealing with the huge challenges on the procurement side. It is extremely challenging to be able to order goods at all, the prices are going through the roof and also the transport routes, namely from Asia westward, are not designed for the current volumes. I am happy to assure you, dear customers, that we are truly doing everything we can to provide you with your products on time - but there may be backlogs.

Despite all the euphoric moments currently, I still have somewhat of a hard time understanding the extent of the upswing.

Bossard is entering a new field with Smart Factory Assembly. As part of Industry 4.0, digitally managed and traceable assembly processes are becoming the new standard. We have identified these and with our Smart Factory Assembly solutions offer you intelligent assembly tools, guided assembly processes and digital assembly documentation. Get inspired by our highly motivated Smart Factory Assembly team. You'll be impressed.

In the Assembly Technology Experts column, we present the Expert Design service to you. On the one hand, we support you with this expert service in designing your screw connections so that these connections also meet require-

ments. On the other hand, and this is almost more exciting for you to know, we are also happy to help you in the development stage of designing your new products. Value engineering is most possible here. If we find solutions together, for example, to be able to reduce the assembly by 20 %, then this should be actually very exciting.

Our Smart Factory Logistics kitchen is again producing a super innovative application for controlled and efficient inventory management with the "SmartLabel Cloud" solution. Read the report and see the advantages for yourself.

In the Product Solutions column, we show how we handle REACH and RoHS requirements for you so that you know you are in safe hands.

The practical example this time takes us to central Switzerland to the company Leister Technologies AG, which implemented our Last-Mile management in their production with great delight and full satisfaction. The company Leister Technologies AG is a world leader in the production of plastic welding devices for welding thermoplastics.

I wish you a beautiful fall and look forward to mastering the upcoming challenges together with you.

Thank you very much for your appreciated trust and confidence

**PETER KAMMÜLLER**

**General Manager, Bossard Switzerland**

[bomi@bossard.com](mailto:bomi@bossard.com)

# CONTENTS

## 04 **Company News**

*Smart Factory Assembly: The digital transformation in assembly*

## 06 **Assembly Technology Expert**

*Calculation of Bolted Joint: Ensuring the quality and safety of your design*

## 10 **Smart Factory Logistics**

*SmartLabel cloud: The revolutionary cloud chain solution*

## 12 **Product Solutions**

*REACH and RoHS: An introduction*

## 16 **Proven Productivity**

*Leister Technologies AG: Logistics system with a high level of flexibility*

## 22 **Global – local**

*We are wherever you are.*



Online

You can find the PDF edition of the Bossard News online at:  
[www.bossard.com](http://www.bossard.com)



## SMART FACTORY ASSEMBLY

# The digital transformation of assembly



**Smart Factory Assembly optimizes process control, as well as control of tools in manual assembly and makes it possible to track all process steps. Assembly digitization improves process control, and increases process reliability and productivity, which reduces your production costs.**

Interactive assembly instructions digitally provide all the necessary documents and protocols related to the order right at the work station. In addition, all relevant assembly aids and tools for the respective work step can be networked and controlled. In this way, employees are guided dynamically and, if desired, step by step through the assembly process.

The digital transformation of assembly offers maximum process reliability and flexibility, regardless of the batch size and diversity. The available data creates transparency in order to identify the potential for optimization and ensure the traceability of production steps.

**"From the work station to the line – the functionality can be modularly defined, making maximum flexibility and adaptability possible."**

## WHY SMART FACTORY ASSEMBLY?

# The advantages of a digitized assembly



### 1. Transparency

Errors can easily be identified, processes improved and traceability is always guaranteed based on the available production data.



### 2. Performance increase

Shorter training for new employees and more efficiency due to standardized processes.



### 3. Quality assurance

Continuous quality control in every work step and in every tool interaction. The correct sequence of the entire production process is ensured.



### 4. Flexibility

If necessary, employees switch between different production islands for variant production. All common production tools, such as screws, cameras, etc. are compatible.



### 5. Just get started

We offer suitable entry-level offers and professional consultation to get started with digitally transforming your assembly in a pragmatic way.

If you want to take advantage of the benefits of Smart Factory Assembly, then contact us:  
[www.bossard.com/smart-factory-assembly](http://www.bossard.com/smart-factory-assembly)

## OPTIMAL PROCESS CONTROL

# Core components for the way to factory 4.0

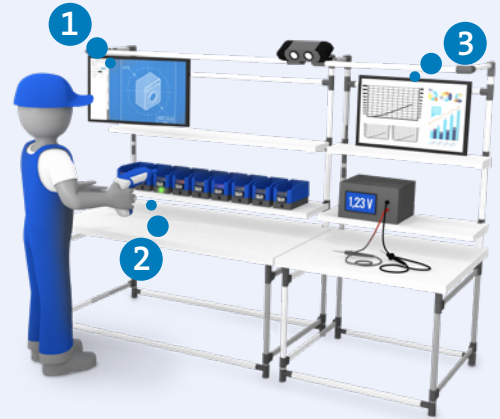

### 1) Digital and interactive work instructions

Centrally created and adjustable work instructions simplify the variant management considerably. The assembly employee is guided through the assembly process and all work steps are automatically documented.

### 2) Connected and intelligent tools

With Smart Factory Assembly, all relevant assembly tools, such as smart screwdrivers, pick-by-light, presses or measuring equipment are networked and can interact with the system.

### 3) Traceability of quality data for continuous process improvement

The production data can be tracked at the product/order level. Relevant production data can be viewed at any time. The transparency gained over the assembly process makes it possible to analyze quickly and easily and to implement improvements quickly.

Find out more  
in our video:





ENGINEERING

# Assembly Technology Expert

## AN EXPERT DESIGN SERVICE

# Calculation of Bolted Joint: Ensuring the quality and safety of your design

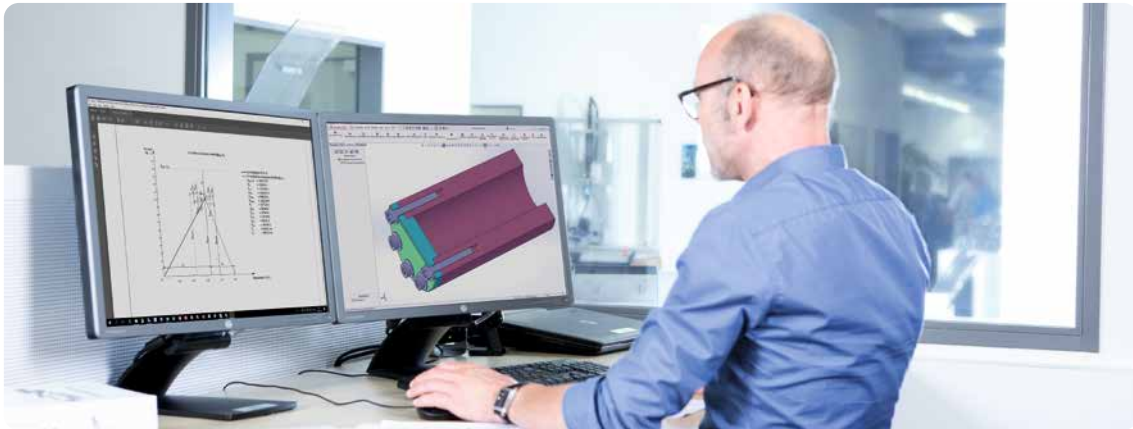

**Have you heard of the VDI guideline 2230? You should have, because the VDI guideline 2230 sets the standards for the quality and safety of high-strength screw connections. We will explain the meaning and the benefits of the guideline and why choosing the right fasteners matters when designing your products.**

### **What is the VDI guideline 2230 about?**

It is a German guideline of the German Association of Engineers (VDI), which was initially developed for the automotive industry and today is recognized worldwide by all industries as the standard work for calculating high-strength screw connections. The guideline describes a systematic procedure for calculating screw connections and explains the interconnections between forces, moments and deformations.

### **Why is the VDI guideline 2230 important?**

These days, all products need to be designed as small and lightweight as possible. That is why it is urgently recommended to perform a calculation of screw connections to ensure that no limit values are exceeded. Since the VDI guideline 2230 describes screw connections that have to transfer constant or alternating working loads, the applica-

tion of the guideline ensures that the screws are designed so that the joined section fulfils its allotted function and withstands the working loads occurring.

### **Where is the customer's benefit?**

For applications where you want to be truly certain that the quality and safety of your screw connection is guaranteed, our specially trained engineers are happy to help you. Our calculations are strictly based on the internationally recognized VDI guideline 2230 and are carried out using the latest software-supported design and calculation methods. We give you a complete screw calculation with all of the relevant information. Applying the guideline reduces your rate of errors and problems to a minimum.

### **What does our service include?**

Based on your specific assembly conditions and interface specifications, our service is aimed at determining the required bolt dimensions and property classes, among other things. In addition to the our bolted joint calculation, we also offer you the verification of results through specific inspections by our Expert Test Services:



SERVICE	WHAT YOU GET	PHASE
<b>Bolted Joint Calculation</b>	<p><b>Design of a reliable fastener for your application.</b></p> <p>Calculations taking all influencing factors into consideration, including the operating loads, in order to guarantee the process reliability of the connection during the specified service life. The calculation is based on the customer's specification and other required assumptions.</p>	<b>Design</b>
<b>Expert Test Services</b>	<p><b>A series of required tests to verify the solution for your application.</b></p> <p>It is also recommended to verify the assumptions made in the design phase by performing various tests. Verifying the initial assumptions includes full test reports for your application.</p>	<b>Verification</b>

You receive from us connections reliably calculated according to VDI guideline 2230 and the certainty that the defined fastener will withstand the tested conditions for the specified service life.

This includes evidence of the load-bearing capability of the screw connection.

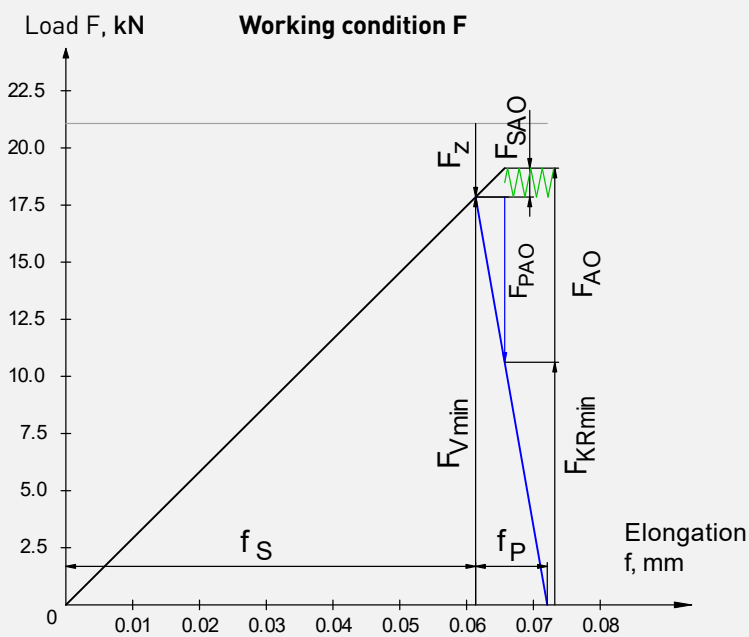

Force-elongation diagram taking operating forces into consideration

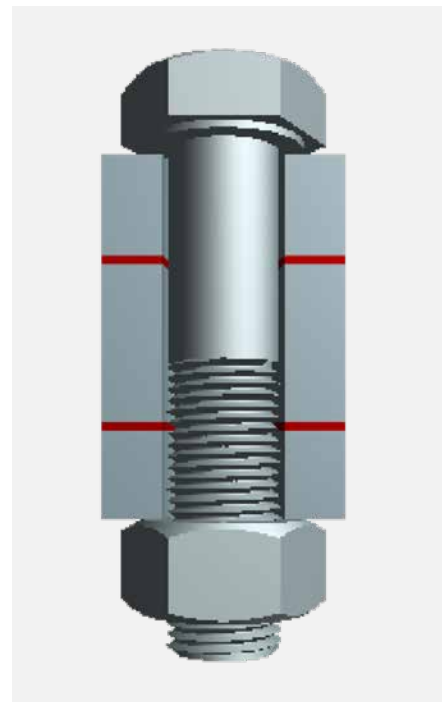

Visualization of the specific customer situation of the screw connection



### Why is Bossard the right partner?

In order to develop your best product, the experts at Bossard offer you a wide range of consultation services and a platform with technical information and tools. Moreover, we believe that you should become an expert in fastening technology. That is why we offer seminars on systematic and need-based qualification of your personnel in the field of fastening technology:

- Calculation of bolted joints (according to the VDI 2230 guideline)
- Functionality of the screw connections
- Selection of the correct fastener
- Determination of the tightening method

Benefit from our expertise and let us help you calculate your bolted joints.

Learn more at: [www.bossard.com](http://www.bossard.com)

SCAN ME



"We are your partner when the quality and safety of screw connections are crucial for your application."



### Scan the QR code above and download our detailed factsheet:

Ensuring the quality and safety of your design: What is the VDI guideline 2230 about and where is the customer's benefit? The free factsheet summarizes the most important information on two pages.

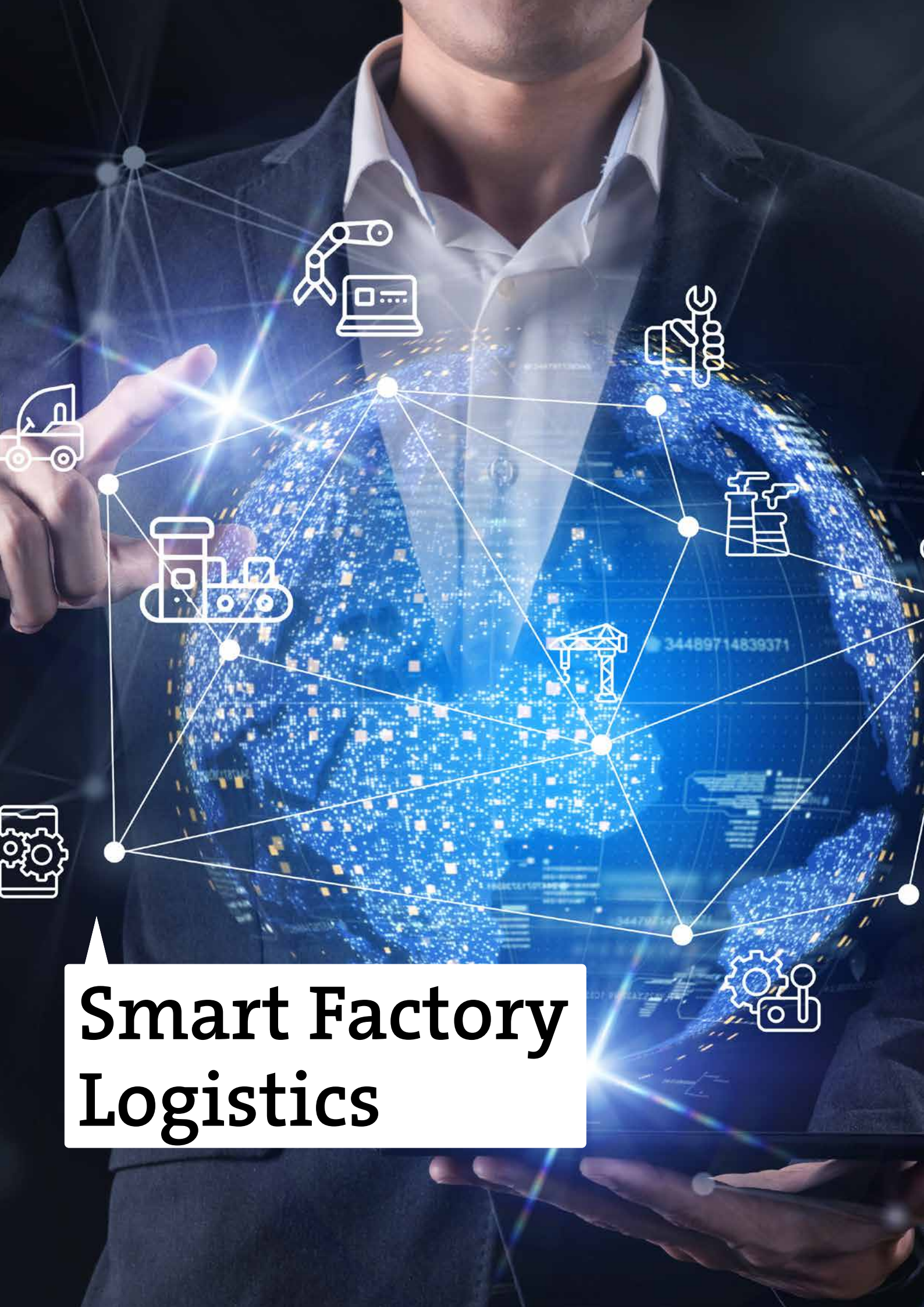

# Smart Factory Logistics

## SMARTLABEL CLOUD

# The revolutionary cloud chain solution

In production processes, internal logistics ensures that all materials are located in the right location at the right time and in the right quantity. Your efficiency has a big impact on total operating costs (TCO).

The new SmartLabel Cloud system from Bossard supports the automation of production processes and helps to keep the total operating costs as low as possible. More efficient work stations increase productivity and have a positive impact on the profit margin.

### What is SmartLabel Cloud?

SmartLabel Cloud is an intelligent and modular label solution that can be used everywhere. All relevant product information, including real-time order status and delivery date, can be read at a glance on the display by using the latest IIoT communication. To put it simpler and clearer: This data makes it easier to get an overview of and control production on site.









Users can trigger orders right from the assembly work station by simply pressing a button. SmartLabel Cloud is based on e-paper technology. The display can easily be read in different lighting conditions thanks to an improved installation position and, thanks to the low energy consumption and a battery service life of up to 5 years, works reliably, sustainably and maintenance-free. SmartLabel Cloud is a modular, comprehensive system that makes it possible to use technical innovations, such as pick-by-light, via LED.



### How does SmartLabel Cloud work?

Once the minimum inventory level is reached, the replenishment order is placed by simply pressing the order button. The data is automatically sent to Bossard online and processed. The order status and delivery date are shown on the SmartLabel. Bossard consolidates the ordered items into one shipment and delivers this to the customer. The current status is shown on the SmartLabel throughout the entire process. Depending on the agreement with the customer, we deliver the material to goods receipt or directly to the assembly work station.

### FEATURES

	<b>CONTROL THROUGH VISUAL VERIFICATION</b>
	<b>WIRELESS</b>
	<b>MOBILE</b>
	<b>ADAPTABILITY</b> - Use of existing infrastructure
	<b>REAL-TIME DATA</b>
	<b>FULL ORDER CYCLE CONTROL</b>
	<b>LED</b> - Pick-by-light option
	<b>ARIMS</b> - Access to the operation dashboard



Would you like to learn more about SmartLabel Cloud?

Then contact us at [www.bossard.com](http://www.bossard.com)





PRODUCTS

# Product Solutions



# AN INTRODUCTION TO EU DIRECTIVES

## REACH and RoHS

REACH and RoHS are regulations of the European Union and are decisive for trade in the EU and within Europe. But how do REACH and RoHS differ from each other and which materials and companies are actually affected by them?



### What is REACH?

REACH is an ordinance of the European Union regarding the Registration, Evaluation, Authorization and Restriction of Chemicals (1907/2006 ordinance). It entered into force on June 1, 2007 and replaced several European directives and ordinances with one uniform system.

It generally applies to all chemicals as individual substances, in preparations or in products if the substance is to be released from a product under normal and foreseeable application conditions.



Galvanized yellow-chromated chromium(VI)-containing screws and linchpins

### What is RoHS?

RoHS stands for Restriction of Hazardous Substances. The EU directive 2015/863/EC (RoHS III) updated the directive 2011/65/EU on the restriction of use of certain hazardous substances in electrical and electronic devices and restricts their use.

Since June 8, 2011, substances subject to these restrictions have not been allowed to exceed a maximum concentration of 0.1 percent by mass in homogeneous materials. Exceptions as per annex III of the guideline allow for the temporary use of specific substances under certain prerequisites.

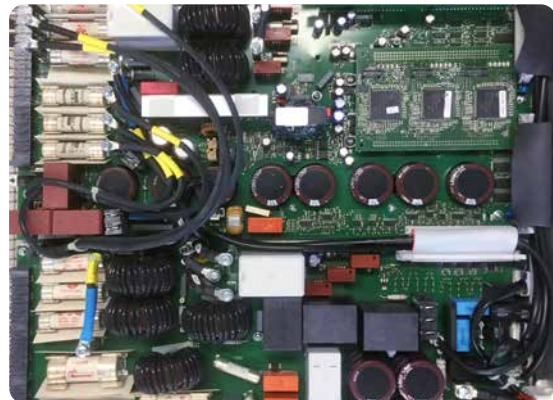

Circuit board with RoHS-relevant components

## What materials are included under the REACH regulation?

REACH restricts the use of many different substances. These substances are listed in the so-called candidate list\*.

### SVHC (Substances of Very High Concern)

When products contain particularly concerning substances (SVHC) with more than 0.1 percent by mass, companies need to inform the commercial customers of this. (Informational obligation as per article 33, para. 1 of the REACH regulation).

### Annex XIV

Annex XIV of the REACH regulation lists the substances requiring approval. Products containing these substances may only be produced, put on the market or used in the EU with approval.

### SCIP database

Since January 5, 2021, companies have been required to report products into the SCIP database that have an SVHC concentration of more than 0.1 percent by mass that are produced, assembled, imported or sold in the EU.

## What companies and products are affected by REACH?

If you produce or import products containing one or more of the substances listed in the candidate list (1 ton or more per year), you must meet the requirements through registration and approval. Otherwise your product will not be approved on the EU market.

### Information obligations within the supply chain

Information and notification obligations may need to be observed when selling products, regardless of whether they originate inside or outside of the EU. For products containing concerning substances as per the candidate list with more than 0.1 percent by mass, there is an obligation as per article 33 of the REACH regulation to automatically provide notification within the supply chain about particularly concerning substances. The supplier is obligated to provide its customer with information that is available to him and that is sufficient for a safe use of the product, but at least must specify the name of the respective substance.

## What materials are included under the RoHS regulation?

The substances prohibited under RoHS from a 0.1 percent by mass in homogeneous materials include:

- Lead (Pb)
- Mercury (Hg)
- Hexavalent chrome (CrVI)
- Polybrominated biphenyls (PBB)
- Polybrominated diphenyl ethers (PBDE)
- Four phthalates (DEHP, BBP, DBP, DIBP)
- Cadmium (Cd) as low as 0.01 percent by mass

There are exception regulations for certain substances and uses. For example, the following exceptions apply to lead as an alloy element as per annex III and IV\*\*:

- 6a: in steel for processing purposes and in galvanized steel max. 0.35 percent by mass
- 6b: in aluminum max. 0.4 percent by mass
- 6c: in copper max. 4 percent by mass

## What companies and products are affected by RoHS?

Any company that sells electronic products, sub-assemblies or components directly into EU countries or to resellers, distributors or processing companies, who in turn sell products in EU countries, if materials are used that fall under the RoHS regulation.

**RoHS 2** or the directive 2011/65/EU expanded the scope of the original RoHS to all electrical/electronic devices, cables and spare parts in July 2011. The substance use bans of the expanded guideline have applied since July 22, 2019.

**RoHS 3** or the directive 2015/863 from the year 2015 added four additional materials (phthalates/plasticizers) to the original substances list, which however are also only possible to use to a limited extent since July 22, 2019.

\* You will find the current candidate list here: <https://echa.europa.eu/candidate-list-table>

\*\* All exceptions as per annex III and IV can be found here: <https://echa.europa.eu/exemptions-art-4-restrictions-rohs>

### Two examples of concerning substances as per the REACH directive:

**Chromium trioxide (chromium (VI) oxide or chromium trioxide)** is contained both in yellow, black and olive chromates as well as in the zinc flake coating Dacromet. Due to the thin layer thickness of the chrome plating, however, the amount in the product (or sub-product) is well below 0.1 percent by mass. In this respect, there is no information obligation as per article 33 of the REACH regulation.

**Lead** (CAS no. 7439-92-1, EC no. 231-100-4) may occur as an alloy element in machine elements with more than 0.1 percent by mass with respect to the respective product in the following strength classes / materials:

- Strength classes: 4.6, 4.8, 5.8, 6.8, 04, 4, 5, 6, 14H, 17H, 22H, 33H, 45H
- Free-cutting steel
- Copper alloys (e.g. brass, bronze)
- Aluminum alloys

The classification of lead as toxic to reproduction does not mean that materials containing lead pose an immediate danger. There are health hazards associated with processing these materials. The potential toxic properties of lead have also been known for years and must be taken into consideration accordingly. In addition, the corresponding occupational protection and disposal regulations are to be observed.

### How can REACH and RoHS be distinguished from each other?

REACH is a general regulation and deals with the manufacture and use of chemical substances and their possible effects on human health and the environment. REACH is monitored by ECHA (European Chemical Agency) and regulates all chemicals that could be used to manufacture a product, including solvents and paints. RoHS, on the other hand, is much more narrowly written and regulates substances that are contained in electrical/electronic devices as well as in medical devices.

*REACH and RoHS are becoming increasingly less congruent, which means a "REACH-compliant" product is not necessarily also "RoHS-compliant".*



Expert Test Services – Spectral analysis

The professional purchasing department at Bossard always ensures that our products meet currently applicable EU legislation. Suppliers from countries outside the EU are asked to provide information about SVHC substances contained in their products. Our 15 ultra-modern testing laboratories around the world mean we are always able to check the product quality of our manufacturers. **Of course, you as a customer can also directly benefit from our expert test services.** You can find more information [here](#).

For more details and if you have questions, please contact your Bossard contact partner at any time:  
[www.bossard.com](http://www.bossard.com)

SCAN ME





LEISTER TECHNOLOGIES AG

## Logistics system with a high level of flexibility







**As an innovative Swiss company, Leister Technologies AG relies on the last mile management of Bossard AG. In order to optimize internal processes right down to the production lines, Leister Technologies AG decided to modernize its C-parts procurement (previously Kanban 2-box system). The aim was to find an Industry 4.0-suitable, paperless and efficient solution for about 600 different items.**

#### **50% cost savings**

These items are now stored in a central supermarket. The SmartBin Flex developed by Bossard automatically ensures item availability. The new concept has meant Leister Technologies AG could lower costs for managing and storing these items by 50%.

#### **Industry 4.0 ready**

With the Last Mile Management - LMM for short - from Bossard, about 1,000 items are managed at 80 work stations. SmartLabel triggers the order directly on the assembly line, which automatically creates a digital picking list. This picking list is then processed by Leister intralogistics or by Bossard logistics. This simplifies the flow of goods and contributes significantly to increasing efficiency.

All C-parts data can be viewed via the Bossard ARIMS app. This app is intuitive and can be accessed by employees on site via a tablet, on a PC or on a smartphone.



### **Small quantity orders via smartphone**

The paperless and simple order processing via smartphone for small parts warehouse of the development department at Leister Technologies AG was particularly convincing.

The core product range for the development department includes about 200 items, which are provided with the Bossard ARIMS app as needed.

The app is used to replenish the supplied items always in the right place - paperless, efficient, independent. This means the next prototypes can be assembled without wait times.



### **Holistic logistics concept**

Leister is convinced by the efficiency of Bossard's logistics solutions. The following advantages result from the implementation:

- Optimization of the material flow
- Increased efficiency by reducing work steps
- More flexibility in conversions
- Integration of all items in one system

*"Bossard AG excited us with their new logistics solution and met our requirements. During the year, we'll take inventory again to possibly expand the system further."*

*Fabienne Rohrer, Procurement Engineer*

**Leister Technologies AG strives to maintain a high product availability for its global customer base. To achieve this goal, modern logistics systems are used for production planning and material management.**

Learn more about Bossard's Last Mile Management or contact us directly:  
[www.bossard.com](http://www.bossard.com)

SCAN ME



### **Plastic Welding Equipment Leister. We know how.**

The Leister Group is a globally operating Swiss technology group with its headquarters in the canton of Obwalden in Central Switzerland. Managed by president of the board Christiane Leister and Group CEO Martin Zingg, the technology group is continuously growing and employs around 900 workers globally, 580 of them in Switzerland. Exports make up 98%.

The Leister Group includes Leister Technologies AG with subsidiaries on three continents and around 130 sales and service centers in more than 100 countries, as well as Axetris AG and its employees in the Leister foreign subsidiaries.

#### **Leister Technologies AG**

Leister Technologies AG has been the global market and technology leader for plastic welding equipment for welding thermoplastic plastics in construction, trade and industry for over 70 years.

#### **Research and development**

One of Leister AG's core competencies is plastics processing. The development of new and existing product is continuously pushed ahead with great gusto.

## GLOBAL - LOCAL: BOSSARD SWITZERLAND

Customer proximity is a key value for long-term and lasting partnerships in a global market environment. That's why we are wherever you are.





AS OF 1 NOVEMBER 2021

## KVT-FASTENING IS INTEGRATED INTO THE PARENT COMPANY, BOSSARD AG

Bossard acquired the company KVT-Fastening in 2012 and since then has successfully continuously developed it further at the Dietikon location. You as a customer benefit from the consolidation in Zug through an even more comprehensive product and service offering from a single source. As a customer of KVT-Fastening, you can also count on technical know-how and your known contact partners in the future as well.

As part of the merger of the two companies, bonding technology department of KVT-Fastening will be transferred to an independent company.

### KDT AG

KDT AG (bonding and metering technology) will continue to operate with existing office and field staff at the existing location in Dietikon. With the newly founded company, KDT is focusing on bonding and metering technology. You as a customer of KDT will continue to receive the well-known brands of Loctite, Kömmerling, Scapa, 3M, Araldite, KDG, KUV and Tapeko.

**We are convinced we will be able to advise and service you even better in the future as a partner in joining technology.**

## SWITZERLAND INNOVATION PARK BIEL/BIENNE

# Bossard gets involved in the spirit of innovation in the heart of Biel/Bienne



The Switzerland Innovation park Biel/Bienne (SIPBB) will be a research center on the topics of Industry 4.0, energy storage, advanced manufacturing and health technology just a two-minute walk from the Biel train station. Together with partners from the industry, research results will be implemented in marketable solutions in an accelerated manner.

In the 5-story building, the SIPBB offers a unique offering of space, technologies and R&D services. In addition to access to key technologies, in the future visitors will also have access to a large network. The SIPBB is part of the national and international network of the Switzerland Innovation Foundation. The project was launched to bring international research projects to Switzerland.

The term “Smart Factory” is on everyone’s lips. This is the case, even though there is still no uniform definition. It usually refers to a holistic, networked production environment, which is based on the latest technological standards. Numerous aspects of production can be solved more “smartly” than before in the Smart Factory. Relevant key figures can be recorded transparently at all times thanks to the consistently digitized production process and used for optimization. The saves resources and is sustainable.

The Swiss  
Smart Factory  
is a unique  
test and  
demonstration  
platform for  
the factory  
of the future

## Bossard at the Swiss Smart Factory

The SIPBB develops and operates different industrial demonstration plants, which illustrate the potential of Industry 4.0 in a practical way. Bossard - as a pioneer in the "SmartBin" and "SmartLabel" systems - is involved in order to take advantage of the mutual exchange of knowledge. You will find the following Bossard installations in the Swiss Smart Factory:

- The lighthouse project is to use a whole production ecosystem to show how Industry 4.0 can already work today. Visitors to the Swiss Smart Factory can follow the whole product life cycle along the production ecosystem - from the product design to the **assembly work station on Bossard** to packaging.
- The new, fully comprehensive **SmartBin Cloud** takes care of managing the electronic components of the drones produced in the Swiss Smart Factory at the work station. The weight sensor is triggered by movement and updates the stock and order information every time it is used (the removal or refilling of material). The order status and all product information are always visible at a glance on the display.
- Since assembly drones has a high variance in components, **Smart Factory Assembly** - the interactive and digital assembly instructions - supports and provides proof that the components were correctly assembled.
- Bossard uses **Last Mile Management System** for internal material distribution to ensure an optimal material flow.



## Optimal cooperation through data consistency

Technologies are not used individually, but rather together in order to establish a smart production and generate greater added value. The focus is not only based on machines here. The entire environment, the building, the infrastructure as well as intelligent logistics systems, like those that Bossard offers, and the machines need to interact.

The Swiss Smart Factory already has numerous members from industry and research and brings together relevant players - major companies, SMEs, start-ups and research partners. Bossard is also involved with innovations in the areas of logistics and digitized assembly in order to shape the establishment, continued development and operation of the state-of-the-art Industry 4.0 demo factory with a lighthouse character for the Swiss workplace.



SmartLocker and the new SmartBin Cloud

*Bossard congratulates SIPBB on the opening of the great Swiss Smart Factory and is proud to be a partner.*

If you would like to learn more about Bossard in the Swiss Smart Factory, then contact René Bächler, [rbaechler@bossard.com](mailto:rbaechler@bossard.com), Head of Smart Factory Logistics

---

[www.bossard.com](http://www.bossard.com)