



ecosyn[®]-BCT Blind rivet nuts

A sustainable solution based on controlled deformation



“Smart, safe and efficient high-quality products borne from innovative engineering – our ecosyn[®]-BCT line of fastening solutions will make it simple for you to turn challenges into opportunities. This is what we call simplicity at work.

This is what we call ecosyn[®]-BCT.”

Contents

Characteristics	4
Technical information	5 – 9
ecosyn®-BCT blind rivet nuts Multigrip, Bulge Control, High Strength, Micro	
ecosyn®-BCT blind rivet nuts Multigrip Flat head, open Low Profile Head, open	10 – 11
ecosyn®-BCT blind rivet nuts Bulge Control Flat head, open Low Profile Head, open	12 – 13
ecosyn®-BCT blind rivet nuts High Strength Flat head, open Low Profile Head, open	14 – 15
ecosyn®-BCT blind rivet nuts Micro Flat head, open Low Profile Head, open	16 – 17
Hand tool	18

BCT is a registered trademark of BBA srl.

Technical performances, installation recommendations as well as unspecified tolerances regarding the dimensions of the parts have to be requested individual for each application before starting the series production.

All dimensions are specified in mm.

CHARACTERISTICS

ecosyn[®]-BCT

A sustainable solution based on controlled deformation.

Innovation is part of our DNA

With the ecosyn[®]-BCT line of products we developed innovative fastening solutions. These high-quality fastening elements are economical and in sync with the needs of our customers. Smart, safe and efficient high-quality products borne from innovative engineering – our ecosyn[®]-BCT line of fastening solutions will make it simple for you to turn challenges into opportunities. This is what we call simplicity at work. This is what we call ecosyn[®]-BCT.

ecosyn[®]-BCT

Bulge Control Technology (BCT) rivet nuts offer versatile and high performance solutions to many blind rivet nut applications. ecosyn[®]-BCT, with four cross holes on the shank, determines precisely where the rivet nut will collapse allowing it to be installed in many non-conventional blind applications.

Applications

Rivet nuts are ideal in tight spots or where performance demands are high, such as in thin-walled, high-tensile, soft, porous or sandwich materials. They are suitable for use in glass- and carbon-fiber reinforced structures, lightweight honeycomb panels, profiles, ductwork and other hard-to-access types of structures.

Benefits

- BCT provides strong threads compared to all other rivet nuts.
- Easy assembling to poorly prepared or oversized holes.
- Can be assembled into the most delicate materials, plastics, composites wood and many other materials.
- Also ideal for marine, medical and petro chemical applications.

3-D Data: <https://bossard.partcommunity.com/3d-cad-models>

TECHNICAL INFORMATION

Multigrip blind rivet nut

With a ecosyn®-BCT Multigrip blind rivet nut you can depending on the thread size cover a grip range of up to 9 mm. To cover such a wide grip range, usually two or three different standard blind rivet nuts are required.

Installation possibilities	Disadvantages of a standard blind rivet nut	Features and benefits of the ecosyn®-BCT
Material thickness is not completely defined	The standard grip range of a common blind rivet nut is around 2.5 mm. If the incorrect grip range is chosen, the rivet nut will not set properly: Is the grip range chosen too small, the bulge can't form properly. If the grip range is too large, the result is an excentric thread position.	With the ecosyn®-BCT Multigrip blind rivet nut you can dependent on the thread size cover a grip range of up to 9 mm. This reduces the risk of using the wrong blind rivet nut for the wrong grip range or application.
Variable material/grip thickness	<ul style="list-style-type: none">▪ If blind rivet nuts of the same thread size are used in many applications with different material thickness, there is a high risk of part mix-up.▪ The limited grip range for a standard blind rivet nut requires stock-keeping of many different blind rivet nut sizes.	As the ecosyn®-BCT blind rivet nut covers a very wide grip range, there is almost no risk for part mix-up. Also the number and variety of blind rivet nuts can be reduced by using only one ecosyn®-BCT rivet nut with a wide grip range.

Installation possibilities



TECHNICAL INFORMATION

Bulge Control blind rivet nut

Bulge Control stands for pre-defined deformation of the bulge without hole filling in the base material. To ensure this setting characteristic, we will design the length and hole position of the ecosyn®-BCT rivet nut appropriate to the given base material dimensions. Thereby, the bulge will be formed at the backside of the application assuring the accurate fit of the blind rivet nut.

Installation possibilities	Disadvantages of a standard blind rivet nut	Features and benefits of the ecosyn®-BCT
Establish a resilient female thread in brittle material (e.g. carbon and glass fiber boards, ceramics) and soft materials (wood, unreinforced plastics, cardboard, rubber)	During the bulging process, the standard blind rivet nut needs to be supported by the inner area of the hole. Thus, a setting force will be applied to the base material, which could lead to damage at the component.	The ecosyn®-BCT blind rivet nut forms the bulge independently applying minimal bearing stresses around the base material, thus preventing damage to it. The distinctive bulge enables a low blind side protrusion.
Establish a resilient female thread in composite panels	The bulge forming starts randomly at the weakest section of the deformation area.	The controlled deformation assures exact positioning of the blind side bulge.
Establish a resilient female thread in a blind hole with base material up to brinell hardness 35 (e.g. oakwood, chipboard, medium density fiberboard)	When a standard blind rivet nut is set into a blind hole, the bulge forms uncontrolled.	The ecosyn®-BCT blind rivet nut forms a controlled positioned bulge in blind hole applications, providing a resilient connection with the base material.
Optimal fitting in irregular, not perfectly round or oversized holes	While bulging, the shank of a standard blind rivet nut needs support from the hole edge. If the hole diameter is out of specification or not perfectly round, the bulge setting can be slanted and not concentric, reducing strength.	The deformation process of the ecosyn®-BCT rivet nut starts with the controlled bulging and continues with a constant deformation till the bulge is plane on the base material.
Rivet two or more components together	If the application consists of two or more elements with gaps in between, the bulge could possibly deform into the gap, as the standard bulge forming is not a stable process.	With controlled deformation, two or more materials are drawn together with flange and bulge then clamped, similar to standard rivet applications.

TECHNICAL INFORMATION

Bulge Control blind rivet nut

Installation possibilities

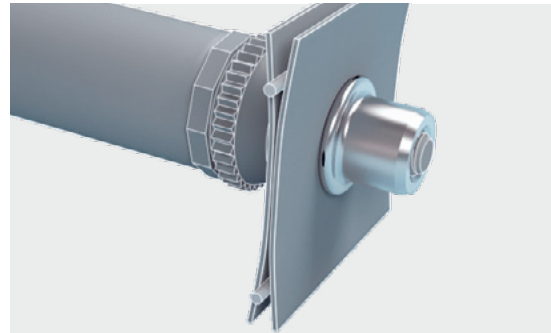
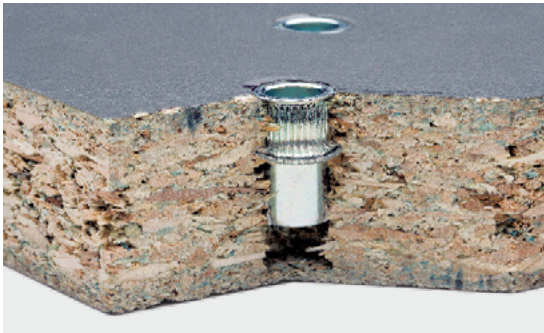

TECHNICAL INFORMATION

High Strength blind rivet nuts

With this blind rivet nut made of steel or aluminum, a resilient thread can be brought into all materials.

Installation possibilities	Disadvantages of a standard blind rivet nut	Features and benefits of the ecosyn®-BCT
Create a connection point for high strength screw joints	It is not possible to get a proper bulge forming at rivet nuts made of high grade material. To bear higher application loads, either the number of rivet nuts, or the thread diameter has to be increased.	With the BC-Technology we can produce blind rivet nuts in high grade material. A High Strength ecosyn®-BCT blind rivet nut in steel, is able to outlast the tensile strength of a 12.9 screw, a High Strength ecosyn®-BCT rivet nut in aluminum is able to bear the tensile strength of a 8.8 screw.

Installation possibilities

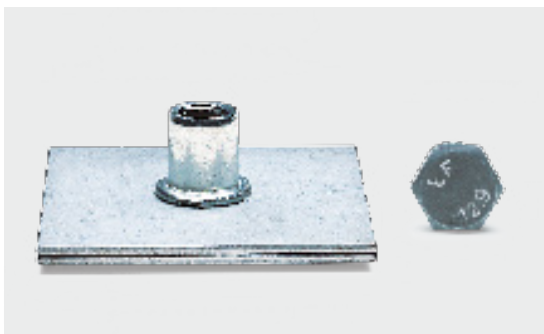

TECHNICAL INFORMATION

Micro blind rivet nuts

Through its very short construction form, the ecosyn®-BCT Micro blind rivet nut enables thread joints also in applications with very limited space. The reduced shank length brings additional weight savings. The ecosyn®-BCT Micro is suitable for grade 8.8 screws in steel.

Installation possibilities	Disadvantages of a standard blind rivet nut	Features and benefits of the ecosyn®-BCT
Create fixation points with very low blind side protrusion for applications like sandwich panels (e.g. M6 in 10 mm aluminum sandwich panel) or round and square tubes with small diameters.	<ul style="list-style-type: none"> ▪ When space is limited, e.g. at small diameter tubes or interfering edges, standard blind rivet nuts cannot be used due to their blind side length. If the bulge of the rivet nut has no contact to the base material while setting, the setting will not be correct. ▪ The flange of a standard blind rivet nut must rest on the base material during the setting process. This requires that the blind side space matches the length of the unset blind rivet nut. 	<ul style="list-style-type: none"> - BC-Technology enables the use of higher grade materials requiring less threads and a shorter blind rivet nut. - Moreover, the flange (head) doesn't need to rest on the base material for proper setting of the Micro blind rivet nut. It is only necessary that the cross-holes stick out about 1 mm off the back material; then the flange will be pulled against the front material.
Weight optimized joint	A standard blind rivet nut is always longer and heavier than the comparable ecosyn®-BCT Micro with the same performance.	As ecosyn®-BCT uses higher grade material for the blind rivet nuts, we are able to produce shorter threads and lighter blind rivet nuts.

Installation possibilities



FLAT HEAD, OPEN

Blind rivet nut | Multigrip



BN	Typ shank	Material
23290	BM/FK round shank	Aluminum AL
25043	BM/FK round shank	Steel, thick coat passivated (RoHS compliant) ST
23397	BM/FK round shank	INOX A2
23311	RBM/FK knurled shank	Aluminum AL
25529	RBM/FK knurled shank	Steel, thick coat passivated (RoHS compliant) ST
23310	RBM/FK knurled shank	INOX A2

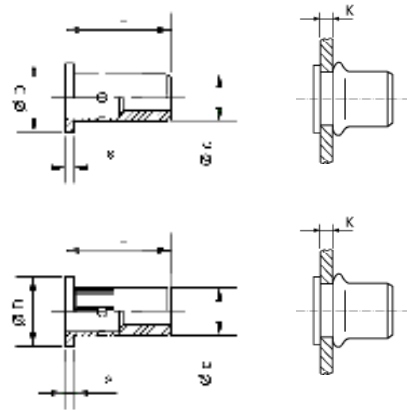

Ordering data

example:

BN 25529	-	M6-45	RBM/FK	ST
----------	---	-------	--------	----

Bossard Number BN

Thread size M6 + code indicating grip range

Type knurled shank

Material steel

Thread	Grip range K	Code	Hole-Ø d	Head-Ø D	Head height S	Length L
M4	0.5 – 4.0	40	7.0	10.0	0.8	14.0
	2.5 – 5.5	55				15.5
	4.0 – 7.0	70				17.0
M5	0.5 – 5.0	50	8.0	11.0	1.0	17.0
	3.0 – 7.0	70				19.0
M6	0.5 – 4.5	45	9.0	13.0	1.5	17.5
	0.5 – 6.0	60				19.5
	4.0 – 9.0	90				22.5
M8	0.5 – 6.0	60	11.0	16.0	1.5	20.5
	0.5 – 8.0	80				23.0
	4.5 – 11.0	110				26.0
	6.5 – 13.0	130				28.0
M10	0.8 – 7.0	70	13.0	19.0	2.0	26.0
	1.5 – 10.0	100				30.0
	5.5 – 14.0	140				34.0

Subject to change without notice. Please refer to your local Bossard E-Shop for the current assortment and dimensions. Other variants upon request.

LOW PROFILE HEAD, OPEN

Blind rivet nut | Multigrip



BN	Typ shank	Material
23296	BM/KS round shank	Aluminum AL
25044	BM/KS round shank	Steel, thick coat passivated (RoHS compliant) ST
23337	BM/KS round shank	INOX A2
23299	RBM/KS knurled shank	Aluminum AL
25530	RBM/KS knurled shank	Steel, thick coat passivated (RoHS compliant) ST
25532	RBM/KS knurled shank	INOX A2

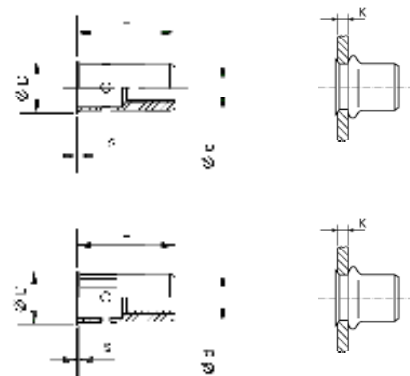

Ordering data

example:

	BN 25530	-	M6-45	RBM/KS	ST
Bossard Number BN					
Thread size M6 + code indicating grip range					
Type knurled shank					
Material steel					

Thread	Grip range K	Code	Hole-Ø d	Head-Ø D	Head height S	Length L
M4	0.5 - 4.0	40	7.0	8.0	0.5	13.5
	2.5 - 5.5	55				15.0
	4.0 - 7.0	70				16.5
M5	0.5 - 5.0	50	8.0	9.0	0.5	16.0
	3.0 - 7.0	70				18.0
M6	0.5 - 4.5	45	9.0	10.0	0.5	16.0
	0.5 - 6.0	60				17.5
	4.0 - 9.0	90				21.0
M8	0.5 - 6.0	60	11.0	12.0	0.6	19.5
	0.5 - 8.0	80				21.5
	4.5 - 11.0	110				25.0
	6.5 - 13.0	130				27.0
M10	0.8 - 7.0	70	13.0	14.0	0.6	25.0
	1.5 - 10.0	100				28.0
	5.5 - 14.0	140				32.0

Subject to change without notice. Please refer to your local Bossard E-Shop for the current assortment and dimensions. Other variants upon request.

FLAT HEAD, OPEN

Blind rivet nut | Bulge Control



BN	Typ shank	Material
26958	BB/FK round shank	Aluminum AL
25045	BB/FK round shank	Steel, thick coat passivated (RoHS compliant) ST
31868	BB/FK round shank	INOX A2
26687	RBB/FK knurled shank	Aluminum AL
25582	RBB/FK knurled shank	Steel, thick coat passivated (RoHS compliant) ST
25552	RBB/FK knurled shank	INOX A2

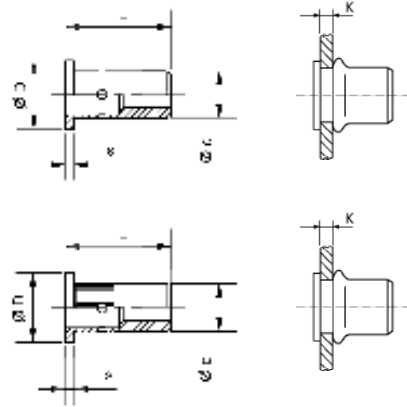

Ordering data

example:

BN 25582	-	M6-25	RBB/FK	ST
Bossard Number BN				
Thread size M6 + code indicating grip range				
Type knurled shank				
Material steel				

Thread	Grip range K	Code	Hole-Ø d	Head-Ø D	Head height S	Length L
M4	0.5 - 1.5	15	7.0	10.0	0.8	14.0
	1.5 - 2.5	25				14.5
	2.5 - 3.5	35				15.5
	3.5 - 4.5	45				16.5
	4.5 - 5.5	55				17.5
M5	0.5 - 2.0	20	8.0	11.0	1.0	17.0
	2.0 - 3.0	30				18.0
	3.0 - 4.0	40				19.0
	4.0 - 5.0	50				20.0
M6	0.5 - 2.5	25	9.0	13.0	1.5	19.5
	2.5 - 4.0	40				20.0
	4.0 - 5.5	55				21.5
M8	5.5 - 7.0	70	11.0	16.0	1.5	23.0
	1.0 - 3.0	30				20.5
	3.0 - 5.0	50				24.0
	4.5 - 6.5	65				26.0
M10	6.5 - 8.5	85	13.0	19.0	2.0	28.0
	1.0 - 3.5	35				26.0
	3.5 - 6.0	60				29.0
	6.0 - 8.5	85				34.0

Subject to change without notice. Please refer to your local Bossard E-Shop for the current assortment and dimensions. Other variants upon request.

LOW PROFILE HEAD, OPEN

Blind rivet nut | Bulge Control



BN	Typ shank	Material
31869	BB/KS round shank	Aluminum AL
25528	BB/KS round shank	Steel, thick coat passivated (RoHS compliant) ST
31867	BB/KS round shank	INOX A2
23297	RBB/KS knurled shank	Aluminum AL
24019	RBB/KS knurled shank	Steel, thick coat passivated (RoHS compliant) ST
24020	RBB/KS knurled shank	INOX A2

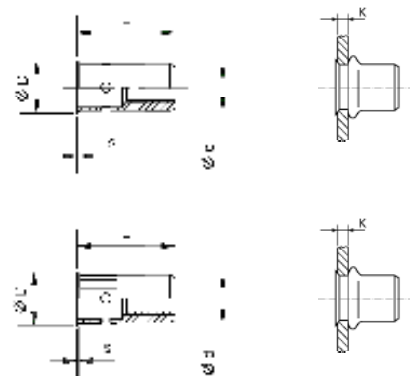

Ordering data

example:

BN 24019	-	M6-25	RBB/KS	ST
Bossard Number BN				
Thread size M6 + code indicating grip range				
Type knurled shank				
Material steel				

Thread	Grip range K	Code	Hole-Ø d	Head-Ø D	Head hight S	Length L
M4	0.5 – 1.5	15	7.0	8.0	0.5	13.5
	1.5 – 2.5	25				14.0
	2.5 – 3.5	35				15.0
	3.5 – 4.5	45				16.0
	4.5 – 5.5	55				17.0
M5	0.5 – 2.0	20	8.0	9.0	0.5	16.0
	2.0 – 3.0	30				17.0
	3.0 – 4.0	40				18.0
	4.0 – 5.0	50				19.0
M6	0.5 – 2.5	25	9.0	10.0	0.5	17.0
	2.5 – 4.0	40				19.0
	4.0 – 5.5	55				20.5
M8	5.5 – 7.0	70	11.0	12.0	0.6	22.0
	1.0 – 3.0	30				20.0
	3.0 – 5.0	50				23.0
	4.5 – 6.5	65				24.0
M10	6.0 – 8.0	80	13.0	14.0	0.6	27.0
	1.0 – 3.5	35				25.0
	3.5 – 6.0	60				28.0
	6.0 – 8.5	85				32.0

Subject to change without notice. Please refer to your local Bossard E-Shop for the current assortment and dimensions. Other variants upon request.

FLAT HEAD, OPEN

Blind rivet nut | High Strength



BN	Typ shank	Material
31863	BH/FK round shank	Aluminum AL
24029	BH/FK round shank	Steel, thick coat passivated (RoHS compliant) ST
31864	RBH/FK knurled shank	Aluminum AL
26715	RBH/FK knurled shank	Steel, thick coat passivated (RoHS compliant) ST

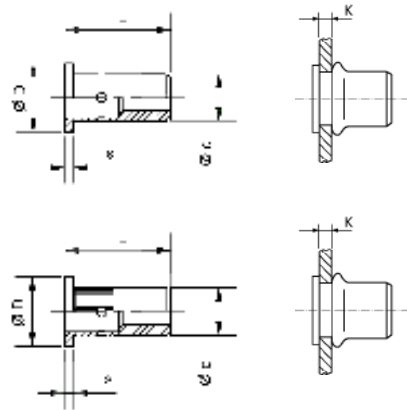

Ordering data example:

	BN 26715	-	M6-30	RBH/FK	ST
Bossard Number BN					
Thread size M6 + code indicating grip range					
Type knurled shank					
Material steel					

Thread	Grip range K	Code	Hole-Ø d	Head-Ø D	Head height S	Length L
M5	0.7 – 2.5	25	8.0	11.0	1.0	16.0
	2.5 – 4.0	40				17.5
M6	1.0 – 3.0	30	9.0	13.0	1.5	19.0
	3.0 – 5.0	50				21.0
M8	1.5 – 4.0	40	11.0	16.0	1.5	23.0
	4.0 – 6.0	60				25.0
	6.0 – 8.0	80				27.0
M10	2.0 – 5.0	50	14.0	19.0	2.0	28.0
	4.5 – 7.0	70				30.0
	6.5 – 9.0	90				32.0

Subject to change without notice. Please refer to your local Bossard E-Shop for the current assortment and dimensions. Other variants upon request.

LOW PROFILE HEAD, OPEN

Blind rivet nut | High Strength



BN	Typ shank	Material
24030	BH/KS round shank	Steel, thick coat passivated (RoHS compliant) ST
24021	RBH/KS knurled shank	Steel, thick coat passivated (RoHS compliant) ST

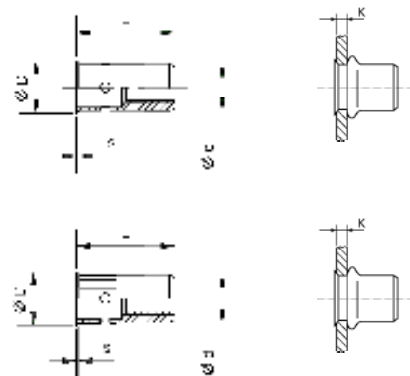

Ordering data example:

	BN	24021	-	M6-30	RBH/KS	ST
Bossard Number BN						
Thread size M6 + code indicating grip range						
Type knurled shank						
Material steel						

Thread	Grip range K	Code	Hole-Ø d	Head-Ø D	Head height S	Length L
M5	0.7 – 2.5	25	8.0	9.0	0.5	15.0
	2.5 – 4.0	40				16.5
M6	1.0 – 3.0	30	9.0	10.0	0.5	18.0
	3.0 – 5.0	50				20.0
	1.5 – 4.0	40				22.0
M8	4.0 – 6.0	60	11.0	12.0	0.6	24.0
	6.0 – 8.0	80				26.0
	2.0 – 5.0	50				27.0
M10	4.5 – 7.0	70	14.0	14.0	0.6	29.0
	6.5 – 9.0	90				31.0

Subject to change without notice. Please refer to your local Bossard E-Shop for the current assortment and dimensions. Other variants upon request.

FLAT HEAD, OPEN

Blind rivet nut | Micro



BN	Typ shank	Material
25046	BS/FK round shank	Steel, thick coat passivated (RoHS compliant) ST
31866	BS/FK round shank	INOX A2
23317	RBS/FK knurled shank	Steel, thick coat passivated (RoHS compliant) ST
31862	RBS/FK knurled shank	INOX A2

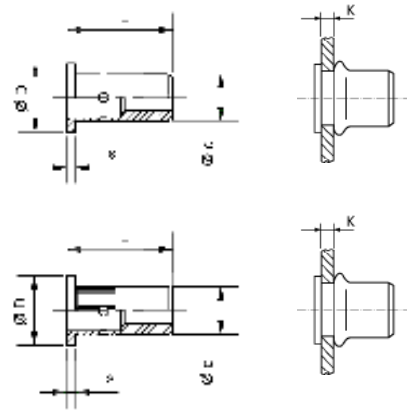

Ordering data

example:

BN 23317 - M6-20 RBS/FK ST

Bossard Number BN

Thread size M6 + code indicating grip range

Type knurled shank

Material steel

Thread	Grip range K	Code	Hole-Ø d	Head-Ø D	Head hight S	Length L
M4	0.5 - 1.8	18	6.0	8.0	0.7	8.0
	1.5 - 2.5	25				8.7
M5	0.7 - 2.0	20	7.0	9.0	0.9	9.5
	2.0 - 3.0	30				10.5
M6	0.7 - 2.0	20	8.0	10.0	1.0	10.5
	2.0 - 3.0	30				11.5
M8	1.5 - 2.5	25	10.0	13.0	1.2	13.0
	2.0 - 4.0	40				14.5
	3.5 - 5.5	55				16.0

Subject to change without notice. Please refer to your local Bossard E-Shop for the current assortment and dimensions. Other variants upon request.

LOW PROFILE HEAD, OPEN

Blind rivet nut | Micro



BN	Typ shank	Material
25047	BS/KS round shank	Steel, thick coat passivated (RoHS compliant) ST
31871	BS/KS round shank	INOX A2
24028	RBS/KS knurled shank	Steel, thick coat passivated (RoHS compliant) ST
24027	RBS/KS knurled shank	INOX A2

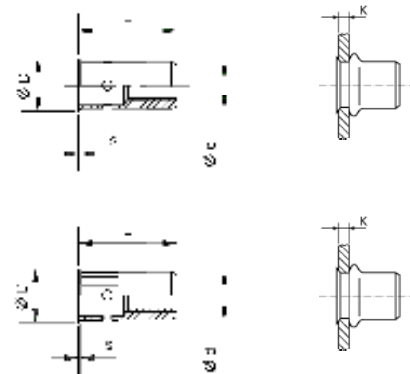

Ordering data

example:

BN 24027 - M6-20 RBS/KS ST

Bossard Number BN

Thread size M6 + code indicating grip range

Type knurled shank

Material steel

Thread	Grip range K	Code	Hole-Ø d	Head-Ø D	Head hight S	Length L
M4	0.5 - 1.8	18	6.0	7.0	0.5	7.8
	1.5 - 2.5	25				8.5
M5	0.7 - 2.0	20	7.0	8.0	0.5	9.0
	2.0 - 3.0	30				10.0
M6	0.7 - 2.0	20	8.0	9.0	0.6	10.0
	2.0 - 3.0	30				11.0
M8	1.5 - 2.5	25	10.0	11.0	0.6	12.5
	2.0 - 4.0	40				14.0
	3.5 - 5.5	55				15.5

Subject to change without notice. Please refer to your local Bossard E-Shop for the current assortment and dimensions. Other variants upon request.

KS 08

Hand tool

- Hand tool for inserting ecosyn®-BCT and FILKO blind rivet nuts
- Weight: Approx. 1.7 kg
- Suitable for:

Blind rivet nuts	Thread sizes
Steel	M4 – M8
Stainless steel	M4 – M8
Aluminum	M4 – M10

- Standard set: M4 – M10

Attention:

ecosyn®-BCT blind rivet nuts version High Strength, steel, cannot be installed by this tool.

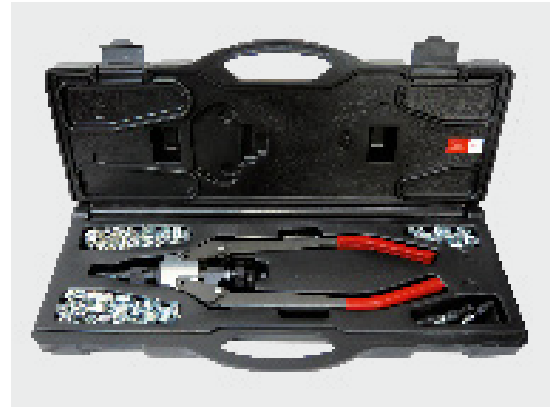

We offer the perfect installation system for every application to ensure safe fitting of blind rivet nuts. A variety of rivet guns with mechanical, hydropneumatic, and electronic drives are available.

For more information and specific offers please visit www.bossard.com

PROVEN PRODUCTIVITY – A PROMISE TO OUR CUSTOMERS

The strategy for success

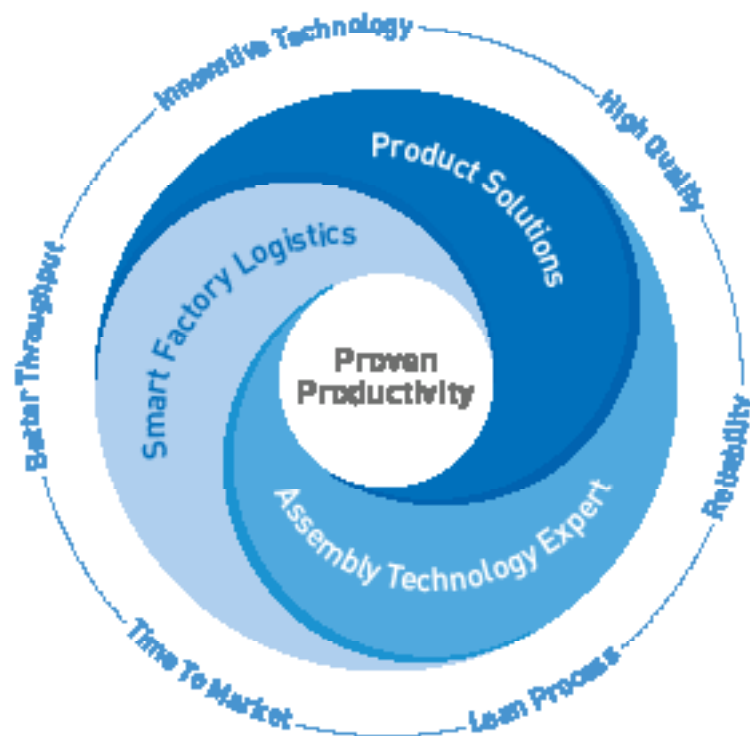

From years of cooperation with our customers we know what achieves proven and sustainable impact. We have identified what it takes to strengthen the competitiveness of our customers. Therefore we support our customers in three strategic core areas.

Firstly, when finding optimal **Product Solutions**, that is in the evaluation and use of the best fastening part for the particular function intended in our customers' products.

Second, our **Assembly Technology Expert** services deliver the smartest solutions for all possible fastening challenges. Our services cover from the moment our customers develop a new product, to

assembly process optimization as well as fastening technology education for our customers' employees.

And thirdly, optimising our clients' productions in a smart and lean way with **Smart Factory Logistics**, our methodology, with intelligent logistics systems and tailor-made solutions.

Understood as a promise to our customers, "Proven Productivity" contains two elements: Firstly, that it demonstrably works. And secondly, that it sustainably and measurably improves the productivity and competitiveness of our customers.

And this for us is a philosophy which motivates us every day to always be one step ahead.

www.bossard.com